

# Enclosed Conductor Rail Xline Overhead Crane Application



**CONDUCTIX**  
wampfler



# Contents

---

## System Overview

---

The Logistics Concept .....	4
The System Components.....	5
Technical Specifications.....	6
Special environmental conditions / physical limits .....	7
Achieve more with the X... swiftly, easily and tool-free .....	8
Smart logistics, too.....	9

---

## System Design

---

Design / materials assortment .....	10
Checking the voltage drop .....	11

---

## System Modules

---

Basic module Xline.....	12
Upgrade set 4- to 5-pole current collector .....	12
Track modules.....	13

---

## Accessories & Optional Components

---

Current collector.....	14
Upgrade set 4- to 5-pole current collector .....	14
Current collector connection cable (option) .....	14
Current collector console (option) .....	14
Chain towing device .....	15
Support arm consoles standard (option) version 1.....	15
Support arm consoles for installation close to the wall (option) version 2 .....	15
Track support bracket, bare to weld on (option) .....	16
Phase control LEDs (option) .....	16
Hanger clamps (additional needs) .....	17
Hanger clamps for higher temperature range and as fall arrest device (option).....	17
Anchor clamps (option).....	17

---

## System sketch

---

---

## Spare Parts & Service Sets

---

Additional current collector .....	19
Upgrade set 4- to 5-pole current collector .....	19
Spare parts package (basic modules).....	19
Spare clamps.....	19
Sliding contact set.....	20
Spare end cap.....	20
Power feed.....	20
Service set.....	20

---

## FAQ

---

---

## Detailed technical design and application information

---

Technical design.....	22
Crane operating modes according to IEC 60034-1 .....	22
Load values for the different operating modes and operating temperatures (ambient temperature) .....	22
Calculation of the voltage drop .....	22
Current load and protection.....	23
Use of the conductor rail .....	23
Cable connection and cable routing of the current collector.....	23
Environmental influences and protection class.....	23
Conductor rail and PE function .....	23

---

## General information

---

We reserve the right to make changes to the product at any time in the course of technical progress without prior notice. All our devices are CE-compliant. Our general terms and conditions apply. We will be happy to send you these on request. Reprinting, even in extracts, is only permitted with our approval.

# System Overview

## The System Components

### End caps

- With snap-in lock

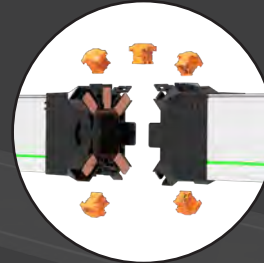
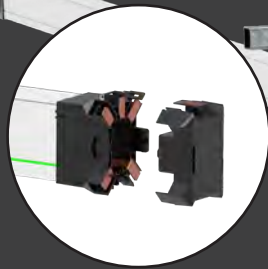

### Profile and conductor strip

- For tool-free assembly

## The Logistics Concept

In addition to the item information, the packaging modules are marked with a colored form elements.

This enables quick identification, even from a distance, simplifies warehouse processes, actively prevents incorrect system combinations and reduces process expenditures and follow-up costs.

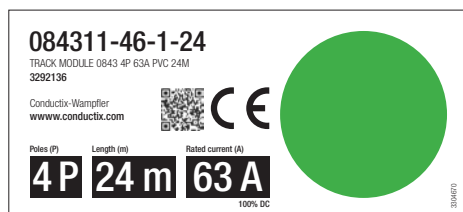

Example: 4-pole track module, 24 m, 63 A

Article	Length	Number of Poles	Amperage (100 % DC)	Color/Symbol	
Basic Modules				<b>B</b>	
Track Modules	4	4	63		
			80		
		5	63		
			80		
		12	4	63	
				80	
	5		63		
			80		
	24	4	63		
			80		
		5	63		
			80		
Parcel Modules		12	4	63	
				80	
	5		63		
			80		

## connection

### Hanger clamps

- With hexagon nut and square nut
- For mounting on 30 mm C-rail

### End feed with system connector

- Power supply with easy access to the terminal strip
- Installation and service labels included
- With integrated anchor clamp
- Optional 3-phase LED display



### Current collector support

- Adjustable
- Optional

### Current collector trolley

- With redundant PE contact (no second trolley required)
- Rated current 34 A (100% duty cycle)
- With integrated connection terminals



# System Overview

## Technical Specifications

<b>Enclosed conductor rail</b>	Xline		
<b>Area of application</b>	Components for creating an energy supply system in the standard crane sector, such as manual overhead cranes, hoists and assembly cranes. For indoor and protected outdoor use (IP2X)		
<b>Protection class (IEC/EN 60529)</b>	IP 2X		
<b>Altitude</b>	< 2000 m above sea level		
<b>Course / length</b>	Straight / up to 100 m (without expansion element)   longer systems possible, depending on voltage drop		
<b>Installation orientation</b>	Horizontal with current collector engagement from below		
<b>Partition</b>	4 m (can be cut to size on the last rail section on site)		
<b>Temperature range</b>	-30 to +55°C		
<b>Operating temperature range</b>	-5 to + 55°C with limited properties below 5°C (generally reduced impact resistance and long-term insulation properties for plastics at low temperatures. See also notes on page 7).		
<b>Max. Temperature change</b>	40°K		
<b>Suspension spacing</b>	nom. 2 m independent of the temperature range		
<b>Number of poles</b>	4 and 5-pole		
<b>Rated voltage</b>	35 to 690 V (UL: 600 V)		
<b>Cross-section / rated current / crane operating modes</b>	cross-section [mm <sup>2</sup> ]	Rated current	Crane operating mode (for details see technical design, page 22)
	10	63 A	S1 - S9
	16	80 A	S1 - S9
<b>Insulating profile</b>	High-grade vinyl-based insulation plastic, weather-resistant		
<b>Dimensions (L x W X H)</b>	Nom. 4000 mm (20°C) x 56 mm x 90 mm (compatible with Program 0842)		
<b>Dielectric strength (IEC 60243-1-3)</b>	30 to 40 kV/mm		
<b>Tracking resistance (EN 69112)</b>	CTI 400-2,7		
<b>Surface resistance (IEC 60093)</b>	10 EXP13 Ω		
<b>Contact resistance (IEC 60093)</b>	5 x 10 EXP 15 Ω/cm		
<b>Reaction to fire (UL 94)</b>	flame-retardant and self-extinguishing according to UL 94 class VO		
<b>Connection</b>	Self-centering plug-in system with latching function (tool-free)		
<b>Conductor strips</b>	Electrolytic copper		
<b>Connections</b>	Via series terminals (current collector) or terminal block (feed-in)		
<b>Current Collector</b>	4-pole (can be upgraded to 5-pole (with upgrade set 5th pole)		
<b>Rated current</b>	34 A (100% duty cycle at 35°C)		
<b>Cable cross-section</b>	4 mm <sup>2</sup> (clamping range 1,5 to 4 mm <sup>2</sup> )		
<b>PE Sliding contact</b>	Redundant 2nd contact (in accordance with DIN EN 60204-32)		
<b>Max. Speed</b>	Max. 150 m/min		
<b>Speed for crane applications</b>	63 m/min (limited in accordance with DIN EN 13557:2009-07 /DGUV for cranes with pendant switches and 80 m/min for hand-held radio transmitter operation)		

# System Overview

---

## Special environmental conditions / physical limits

---

### Low temperature ranges

-30° to -5° C:

All enclosed conductor rails use the plastic body as the supporting element. Plastics are physically limited in their temperature range. At temperatures below freezing point, the breaking strength of plastic decreases and insulation values may change.

This must be taken into account when assessing the application and further measures must be considered. Possible on-site measures at low temperatures as part of the system evaluation: e.g. protection against external influences, installation outside reachable areas and periodic visual inspection and measurement of the insulation parameters after prolonged use.

### Condensing moisture, dust exposure and unprotected outdoor use:

In contrast to single-pole conductor rails, which are installed separately from each other outdoors, enclosed conductor rails have a common insulation body. Condensation caused by rising damp, fog etc. or the accumulation of dust can lead to insulation faults.

In wet conditions and with high dust exposure, box conductor rails have physical limits and, if necessary, single-pole conductor rails should be used.



# System Overview

---

Achieve more with the X... swiftly, easily and tool-free

---

## Unique solution

Xline, with its unique and most rigid honeycomb profile, sets new standards for enclosed conductor rails. The X arrangement of the sliding contacts ensures optimum contact quality and guidance of the collector trolley. The tool-free connection technology enables quick, safe and intuitive assembly. The connector parts guide themselves into position and lock noticeably and audibly. Positioning the conductor strips and connectors in the corners allows good accessibility to the back of the system. The connections can be done without direct line of sight, and with gloves.

## Pre-assembled at the factory

The factory pre-assembled rails have a nominal length of 4 m. Intermediate lengths are possible by shortening the last rail on site, easily and with standard tools.

## No expansion modules

Expansion modules or segments are not necessary. The thermal expansion is compensated within each rail. In addition to cutting down on expansion modules, the mechanical load on the components is reduced.

## Tool-free connector technology

All connection points, including the interface to the power feed and end cap, are designed with tool-free connectors.

Terminal points on the current collector and power feeds are easily accessible, simplifying the installation of the customer's connecting cables and reducing installation time.

## Standards-compliant and long-lasting

The current collector trolley is equipped with high-performance bearings and long-life sliding contacts for a long operating time with high contact quality and redundant protective earth contacts. The use of a second current collector is therefore not necessary, even for inverter operation.

## Swift and safe installation

Xline has been developed for quick and safe assembly in accordance with current international standards. Pre-assembled at the factory and supplied with all the components required for assembly, unnecessary handling and searching, as well as additional set-up and pre-assembly work are avoided.

## Error-free and high assembly quality

Intuitive mounting not only supports fast assembly. It shortens the training period, actively reduces the potential for errors and thus optimizes assembly time and work quality.

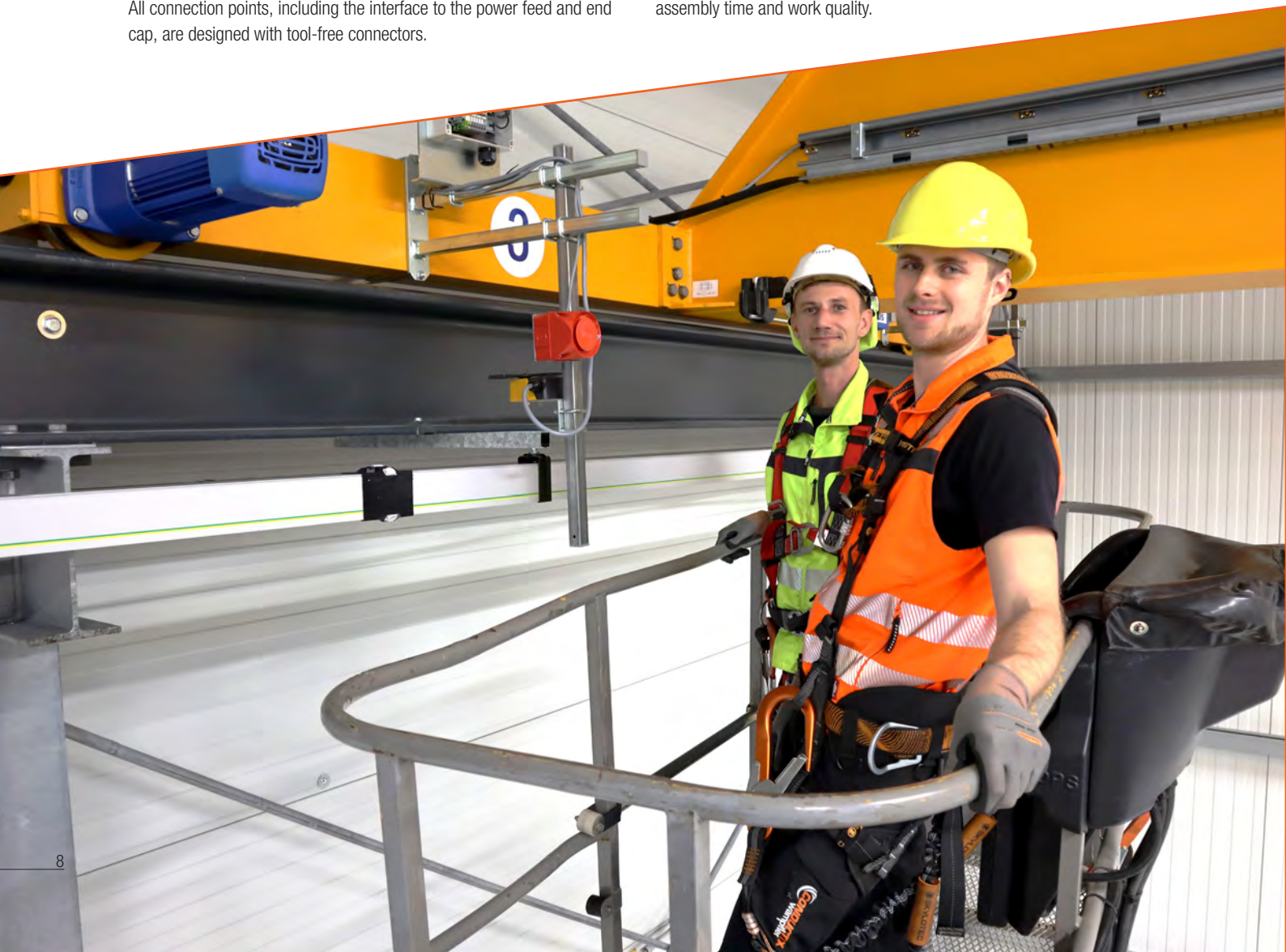

---

## Smart logistics, too

---

### Modular concept

Xline is supplied in modules that can be quickly assembled into the required system. All parts required for a work step or track section are logically arranged in the basic or track modules. Everything is where you need it - and can be found without time-consuming searching!

### Basic modules

The basic module contains all the single parts required for a system. This includes the power feed, an anchor point, an end cap and a set of labels to record the installation date and the next service date. A spare parts package with small parts and documentation are also included. This reduces the quotation, ordering and provision of many individual parts to a single item.

### Upgrade set 4- to 5-pole

For 5-pole systems, the current collector is supplemented with the sliding contact for the fifth pole by means of an optional upgrade set and a few simple steps.

### Track modules

4, 12 and 24 m modules can be provided for the track which, in addition to the pre-assembled rails, contain the hanger clamps and connectors for the conductor rails. This means that all components for the track section are combined and route times are optimized, and there is no need to search for accessories in boxes and cartons.



# System Design

## Design / materials assortment

The system is assembled quickly and easily using the input information from the crane/hoist manufacturer (rated current of the conductor rail, number of poles and length).

- Step 1:** Current and number of poles from the hoist/crane manufacturer's specifications => rail type
- Step 2:** Crane runway length => number of modules from the selection table
- Step 3:** Check voltage drop according to table
- Step 4:** Selection of options

Quotations and orders can also be created via our online shop, by using a configurator!



# System Design

## Checking the voltage drop

Length [m]	32 A		50 A		63 A		80 A	
	10 mm <sup>2</sup>	16 mm <sup>2</sup>	10 mm <sup>2</sup>	16 mm <sup>2</sup>	10 mm <sup>2</sup>	16 mm <sup>2</sup>	10 mm <sup>2</sup>	16 mm <sup>2</sup>
12	0.35%	0.21%	0.54%	0.33%	0.68%	0.42%	0.87%	0.54%
16	0.46%	0.29%	0.72%	0.45%	0.91%	0.56%	1.15%	0.71%
20	0.58%	0.36%	0.90%	0.56%	1.14%	0.70%	1.44%	0.89%
24	0.69%	0.43%	1.08%	0.67%	1.36%	0.84%	1.73%	1.07%
28	0.81%	0.50%	1.26%	0.78%	1.59%	0.98%	2.02%	1.25%
32	0.92%	0.57%	1.44%	0.89%	1.82%	1.12%	2.31%	1.43%
36	1.04%	0.64%	1.62%	1.00%	2.05%	1.26%	2.60%	1.61%
40	1.15%	0.71%	1.80%	1.11%	2.27%	1.40%	2.89%	1.78%
44	1.27%	0.78%	1.98%	1.23%	2.50%	1.55%	3.18%	1.96%
48	1.39%	0.86%	2.16%	1.34%	2.73%	1.69%	3.46%	2.14%
52	1.50%	0.93%	2.35%	1.45%	2.96%	1.83%	3.75%	2.32%
56	1.62%	1.00%	2.53%	1.56%	3.18%	1.97%	4.04%	2.50%
60	1.73%	1.07%	2.71%	1.67%	3.41%	2.11%	4.33%	2.68%
64	1.85%	1.14%	2.89%	1.78%	3.64%	2.25%	4.62%	2.85%
68	1.95%	1.21%	3.07%	1.90%	3.86%	2.39%	4.91%	3.03%
72	2.08%	1.28%	3.25%	2.01%	4.09%	2.53%	5.20%	3.21%
76	2.19%	1.36%	3.43%	2.12%	4.32%	2.67%	5.48%	3.39%
80	2.31%	1.43%	3.61%	2.23%	4.55%	2.81%	5.77%	3.57%
84	2.42%	1.50%	3.79%	2.34%	4.77%	2.95%	6.06%	3.75%
88	2.54%	1.57%	3.97%	2.45%	5.00%	3.09%	6.35%	3.92%
92	2.66%	1.64%	4.15%	2.56%	5.23%	3.23%	6.64%	4.10%
96	2.77%	1.71%	4.33%	2.68%	5.46%	3.37%	6.93%	4.28%
100	2.89%	1.78%	4.51%	2.79%	5.68%	3.51%	7.22%	4.46%

The table shows the maximum length between the infeed point and outfeed = current collector. Calculated with a **starting factor of 1.2 for F/U drives at 400 V and an ambient temperature of 20°C (limit value 4% voltage drop).**

The drives and power supply of standard crane systems are designed for short-time and intermittent operation with a duty cycle of 20% to 40% (< 60 %) and a voltage drop of 4% for the conductor rail (**FEM 9.683**).

The fuse value specified by the hoist/crane manufacturer is used as the input variable here.

For applications (e.g. several cranes per crane runway, magnetic grippers, etc.), the design can be carried out via the sales department or design tools, e.g. in the web store.

# System Modules

## Basic module Xline

Single parts such as end cap, power feed, current collector, etc. are packed in the basic module together with a spare parts package and assembly documentation. The module can be used in combination with all track modules. When using systems with a 5<sup>th</sup> pole, an additional upgrade set for the current collector is required.



### Content

- 1 x power feed with integrated anchor clamp
- 1 x end cap
- 1 x current collector (4-pole)
- 1 x towing device
- spare parts set
- mounting instruction
- labels set

**Part No.: 084312-4x1**

Dimensions: 600 mm x 400 mm x 300 mm  
Weight: 21.4 kg

## Upgrade set 4- to 5-pole current collector

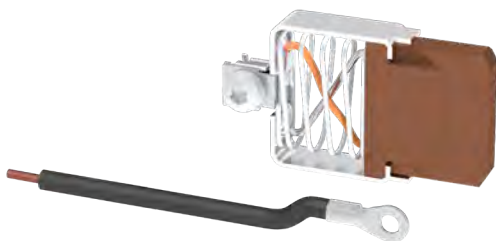

conversion time from 4 to 5 pole current collector: 2-3 mins.

### Upgrade sliding contact to 5-pole collector

The set includes the fifth sliding contact, a prefabricated connecting cable and connection parts. The fifth sliding contact is inserted into the mounting opening on the trolley, screwed together with the connecting cable and the second end of the cable is placed in the terminal strip.

**Part No.: 084394-01**

Weight: 0.1 kg

# System Modules

## Track modules

The modules are available ready to install for 4, 12 and 24 m to build the track. All parts required for the rail section and the connection, such as hanger clamps and conductor strip connectors, are included in the scope of delivery. Adaptation to intermediate lengths is easily possible on site by shortening the last rail.

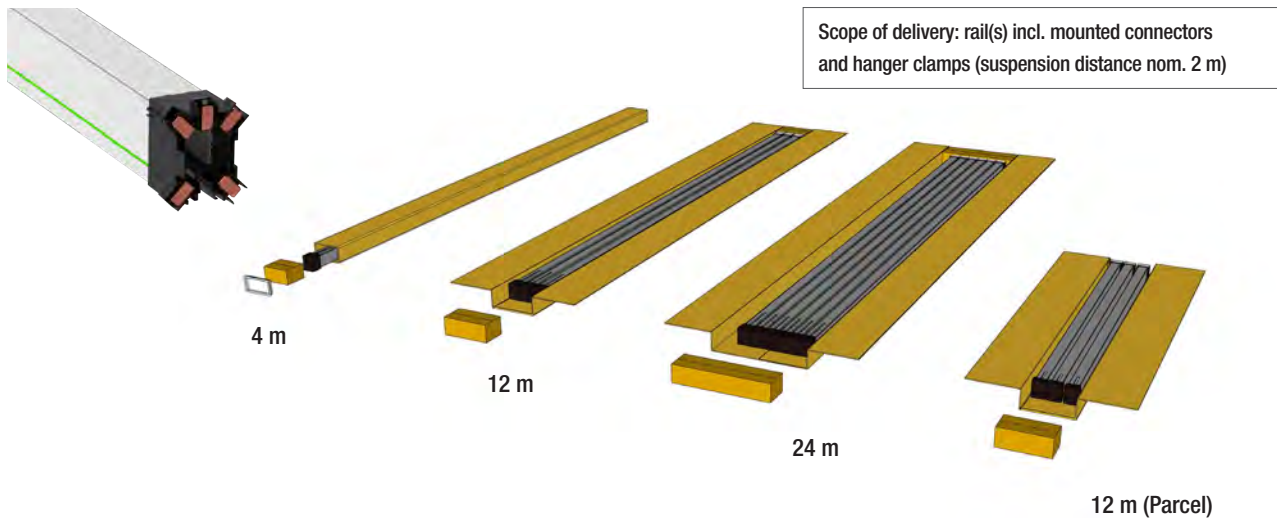

Part Nos. Xline track modules		track modules					parcel modules		
Rated current	Number of poles	4 m (1 x 4 m)	Weight [kg]	12 m (3 x 4 m)	Weight [kg]	24 m (6 x 4 m)	Weight [kg]	12 m (3 x 4 m)	Weight [kg]
63 A	4	084311-46-1-04	5,0	084311-46-1-12	13,7	084311-46-1-24	22,7	084311-46-1-12P	16,9
	5	084311-56-1-04	5,3	084311-56-1-12	14,8	084311-56-1-24	24,7	084311-56-1-12P	17,9
80 A	4	084311-47-1-04	5,9	084311-47-1-12	16,7	084311-47-1-24	28,6	084311-47-1-12P	19,6
	5	084311-57-1-04	6,5	084311-57-1-12	18,5	084311-57-1-24	32,1	084311-57-1-12P	21,0
Dimensions [mm]		4030 x 75 x 160		4400 x 300 x 120		4400 x 600 x 120		2000 x 600 x 120	

With the **parcel modules**, the rails are split in the middle and are joined together on site to form a 4 m rail in just a few simple steps. The conductor strips are packed with the module in a continuous, kink-free U-shape. If necessary, the concept enables shipment by parcel service with a package length of 2 m. A 4 m rail can be assembled from 2 x 2 m sections in approx. 2-3 minutes.

# Accessories & Optional Components

## Current collector



**Current collector trolley 4-pole 34 A 100% DC** with integrated terminal blocks for on-site cable connection.

- Clamping range: 1,5 - 4 mm<sup>2</sup>
- Screw connection: I125
- Cable diameter: 11 - 17 mm

**Part No.: 084301-4x20**

Weight: 1,2 kg

## Upgrade set 4- to 5-pole current collector



### Upgrade sliding contact to 5-pole collector

The set includes the fifth sliding contact, a prefabricated connecting cable and connection parts. The fifth sliding contact is inserted into the mounting opening on the trolley, screwed together with the connecting cable and the second end of the cable is placed in the terminal strip.

**Part No.: 084394-01**

Weight: 0,1 kg

conversion time from 4 to 5 pole current collector: 2-3 mins.

## Current collector connection cable (option)



### Cable type H07RN-F 5G4

- Rubber hose cable
- Number of cores: 5
- Cross-section: 4 mm<sup>2</sup>
- Length: 3 m (configurable)

**Part No.: 131110-R5G4#**

Weight: 0,45 kg/m

Note: The length of the current collector connection cable must not exceed 3 m if the upstream overcurrent protection device is not designed for the load capacity of this connection cable. See also DIN VDE 0100, Part 430 and DIN EN 60204-32 (cranes) in accordance with IEC EN 60204 T32 (cranes).

## Current collector console (option)

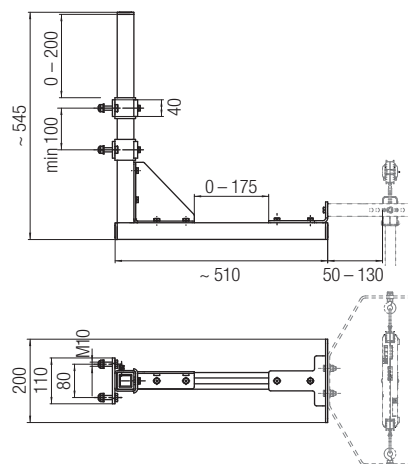

### Console, consisting of C-rails and mounting parts

- Infinitely adjustable and can be shortened (partially pre-assembled)
- Galvanized steel incl. fastening material
- Can be used for single and double towing chain device

**Part No.: 084291-50**

Weight: 6.1 kg

Dimensions: 786 x 284 x 285 mm

# Accessories & Optional Components

## Chain towing device

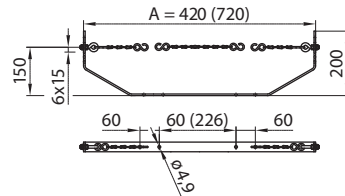

### Towing device for current collector trolleys

- Mounting surface on the side or underneath the current collector
- Chains included in the scope of delivery

Single towing chain arm (A = 420 mm)

**Part No.: 084291-11** Weight: 0.9 kg

Double towing chain arm (A = 720 mm)

**Part No.: 084291-12** Weight: 1.3 kg

## Support arm consoles standard (option) version 1

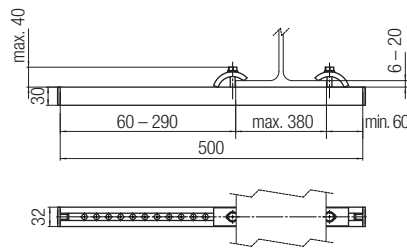

### Fastening set for fastening the enclosed conductor rail to steel girders (mounted with girder clips)

- 5 x support arms | L = 500 mm
- 10 x clamping claws | s = 6-25 mm
- mounting sketch

**Part No.: 084395-03**

Weight: 5.5 kg

Dimensions: 786 x 284 x 285 mm

Universal connection to the track girder using C-rail support arms and girder clips (front and rear)

## Support arm consoles for installation close to the wall (option) version 2

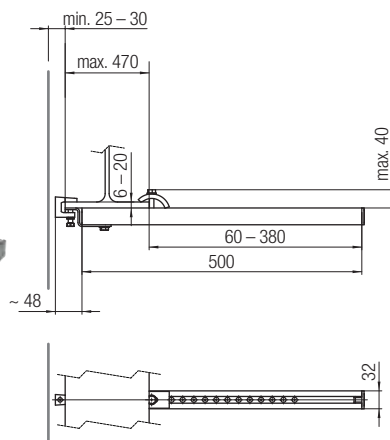

### Fastening set for fastening the enclosed conductor rail to steel girders (installation close to the wall)

- 5 x support arms | L = 500 mm
- 5 x clamping claws | s = 6-25 mm
- 5 x brackets (Z profile) incl. screw and square nut
- 5 x beam clamps
- mounting sketch

**Part No.: 084395-05**

Weight: 6.3 kg

Dimensions: 786 x 284 x 285 mm

Consoles for use with restricted access to the track beam. The rear clamp is clamped to the bottom flange from below using a beam clamp. This ensures that the rail is clamped at the front and rear. This meets the requirements for safety-compliant suspension of the conductor rail.

# Accessories & Optional Components

## Track support bracket, bare to weld on (option)

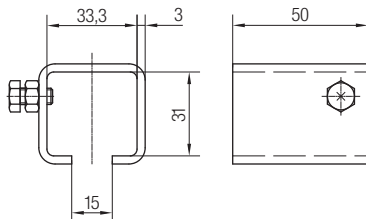

**Part No.:** 023224

Weight: 0.13 kg

Packaging unit: 1 pc.

For further fastening solutions for C-rails, see catalog program 0230.

## Phase control LEDs (option)



The end feed can be upgraded with 3 LEDs for visualizing the phase voltages using the optional retrofit kit. The LEDs are installed in the end feed instead of the dummy cover.

### LEDs

- Pre-assembled connecting cables
- with integrated fuse

**Part No.:** 084394-02

Weight: 0.1 kg

# Accessories & Optional Components

## Hanger clamps (additional needs)

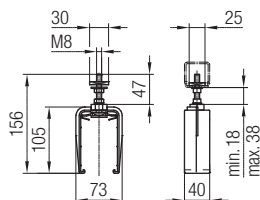

Note: All hanger clamps required as standard are included in the scope of delivery of the track modules.

**Part No.: 08-S280-0895**

Weight: 0.1 kg  
Packaging unit: 1 pc.

## Hanger clamps for higher temperature range and as fall arrest device (option)

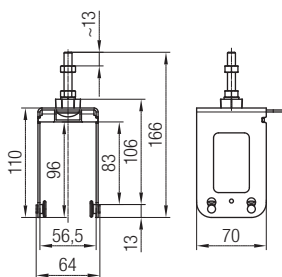

For applications with large temperature fluctuations or exposed locations (risk of damage or critical environmental conditions such as high air pollution with drilling emulsion, aromatic solvents, etc.), hanger clamps with roller supports are recommended.

As a fall arrest device: quantity = 1 x every other rail.

**Part No.: 084245-22**

Weight: 0.4 kg  
Packaging unit: 1 pc.

## Anchor clamps (option)

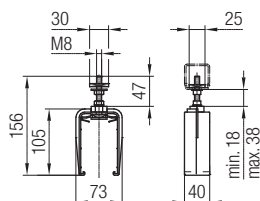

### Anchor clamp

as an alternative to the anchor point integrated in the end feed

**Part No.: 08-F080-0099**

Weight: 0.1 kg

# System sketch

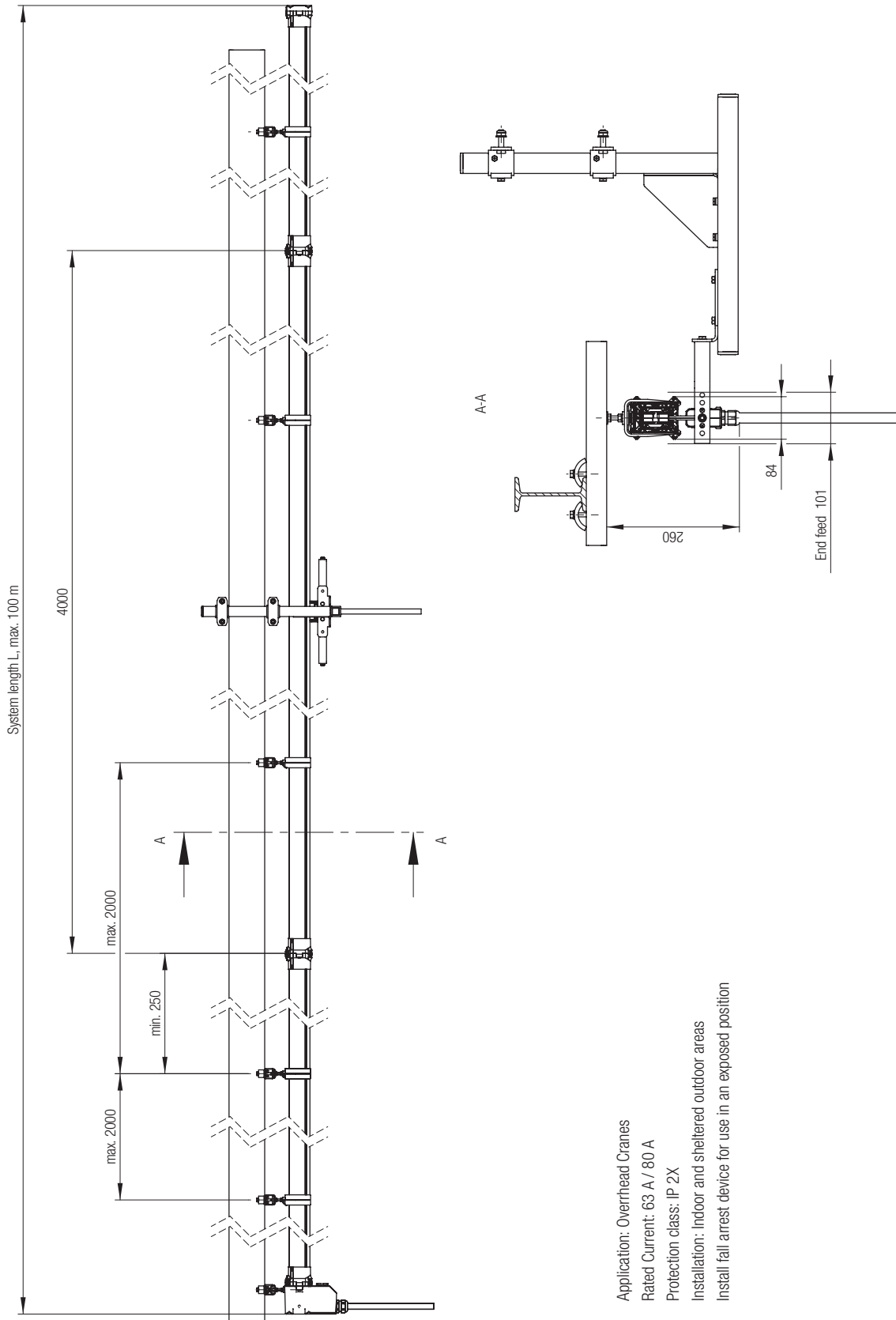

Application: Overhead Cranes  
 Rated Current: 63 A / 80 A  
 Protection class: IP 2X  
 Installation: Indoor and sheltered outdoor areas  
 Install fall arrest device for use in an exposed position

# Spare Parts & Service Sets

---

## Additional current collector

---



### Current collector trolley 4-pole 34 A 100% duty cycle

With integrated terminal blocks for on-site cable connection.

Clamping range: 1.5-4 mm<sup>2</sup>

Cable gland: M25

**Part No.: 084301-4x20**

Weight: 1.2 kg

---

## Upgrade set 4- to 5-pole current collector

---



conversion time from 4 to 5 pole current collector: 2-3 mins.

### Upgrade sliding contact to 5-pole collector

The set includes the fifth sliding contact, a prefabricated connecting cable and connection parts. The fifth sliding contact is inserted into the mounting opening on the trolley, screwed together with the connecting cable and the second end of the cable is placed in the terminal strip.

**Part No.: 084394-01**

Weight: 0.1 kg

---

## Spare parts package (basic modules)

---



**Set as supplied with the basic module. Includes all small parts and spare parts that may be required for assembly.**

- 1 x clamping set (63 A / 80 A)
- 1 x hanger clamps
- 4 x screws for end feed cover/current collector cover
- 2 x tubular cable lug for feed-in 16 mm<sup>2</sup>

**Part No.: 084395-01**

---

## Spare clamps

---

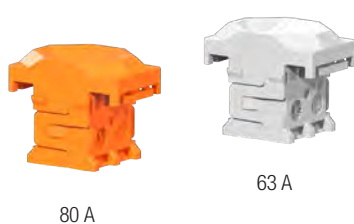

### Spare clamping set

- 10 x 10 mm<sup>2</sup> (grey)
- 10 x 16 mm<sup>2</sup> (orange)

**Part No.: 084395-02**

# Spare Parts & Service Sets

---

## Sliding contact set

---



### Spare sliding contact set

- 5 x spare sliding contacts for 4-pole current collector (for 5-pole version additionally 084394-01 required)

**Part No.: 081007-113S**

Weight: 0.1 kg

---

## Spare end cap

---



### End cap for the rail end

- tool-free

**Part No.: 08437-1**

Weight: 0.2 kg

---

## Power feed

---



### Power feed 63 A / 80 A incl. tubular cable lugs 16 mm<sup>2</sup>

- Cable gland: M40
- Clamping range: 19 - 28 mm

**Part No.: 084351**

Weight: 1 kg

---

## Service set

---



### Spare parts set for the service vehicle with additional spare parts and optional accessories.

- 6 x Hanger Clamps
- 2 x Spare clamping set (10 x 63 A/10 x 80 A)
- 2 x Upgrade set 4- to 5-pole
- 2 x LEDs
- 2 x Labels set
- 1 x End cap
- 2 x Connector cap conductor rail profile
- 1 x Assembly instructions

**Part No.: 084395-06**

# FAQ

---

## Are intermediate lengths also possible?

---

The system is designed in grid lengths of 4m. If necessary, the last rail can be shortened on site with a few simple steps and a metal saw.

---

## Is it possible to use two current collectors to comply with the earthing specifications?

---

The current collector already has a redundant version of the PE contacts, so there is no need for a second current collector.

---

## Why can the conductor rail be subjected to higher loads than cables with the same cross-section?

---

In the conductor rail, the conductors are separated and can dissipate the heat better than in a cable. This means that higher currents are possible with the same heat output.

---

## High currents can flow despite small cross-sections. How is this possible?

---

Standard cranes and hoists are designed for short and intermittent operation. This means that after the lifting or travel movement, a cooling phase takes place due to the design of the crane with limited travel and lifting distance. Standard cranes are designed with a duty cycle of 20 to 40%. This means that with a cycle time of 10 minutes (corresponds to a 100% duty cycle according to the standard), the hoist is in operation for 2(4) minutes and at rest for 8(6) minutes. This means that the load in the active phase can be higher than with a continuous load.

---

## The basic module has a 4-pole current collector. Is there also a basic module with a 5-pole current collector?

---

The basic module contains the 4-pole collector trolley and a conversion kit for the 5th pole (sliding contact and cable section). The conversion to the 5th pole is self-explanatory and can be completed in 2-3 minutes.

---

## The current collector cable is not included. Why?

---

The current collector has an integrated terminal box with a removable cable gland and thus enables a suitable cable to be terminated by the customer. This solution was chosen because every customer requires a different length and cables require a very large space for transportation. To ensure shipping costs and flexibility on the construction site, the cable is supplied by the customer.

---

## Can the connection between the rails be loosened again?

---

The connections are designed so that the conductor rail connectors can be levered out with a screwdriver and the rail connectors can be separated after lifting the latching clamps. Please note that the conductor strip clamps may only be used once.

---

## Are longer lengths over 100 m and higher currents possible, e.g. 200 A as with other systems?

---

The system is optimized for standard crane applications. Lengths of over 100 m are not common in this segment, although they are occasionally encountered. For a plastic-based system, systems longer than 100 m make no technical sense and are detrimental to system availability. The expansion behavior and other effects are critical and a poor compromise. High currents are usually selected because of voltage drop. Here, however, it makes more sense to adjust the position or number of feeds. Systems with greater lengths and higher currents should be designed as single-pole conductor rails. Conductix-Wampfler offers further solutions here.

---

## Can I also obtain the conductor rail as curved elements?

---

The conductor rail is designed for indoor crane applications with straight tracks. For systems with curves, please contact our sales department.

---

## Is the product also available with a higher protection class?

---

Even on enclosed rails, the current-carrying conductor is not covered and an entry for the current collector is required. Fine dust and moisture, especially condensation, can get into the interior. This means that even with seals, only a limited increase in the degree of protection for enclosed conductor rails is possible.

---

## What is the running performance of the sliding contacts?

---

The sliding contacts have a wear range of 5 mm. Under normal conditions, this corresponds to a mileage of approx. 8-10,000 km. With an average mileage of 450 km per year, the sliding contacts are sufficiently dimensioned, but must be checked during crane maintenance.

# Detailed technical design and application information

---

## Technical design

---

The design is carried out in just a few steps

- Determination of the current
- Testing the voltage drop

---

## Crane operating modes according to IEC 60034-1

---

The Xline conductor rail is designed for use in workshop and assembly cranes with a typical duty cycle of 20-40% (duty cycle < 60%).

In this application, the load profile is a non-periodic load and speed profile. This crane operating mode is designated as S9. In this operating mode, the conductor rail can be operated at rated current and short term overload (starting torque).

Cranes that perform only a few load cycles per day are assumed to operate in short-time S2 or intermittent S3 or S4. In all these cases, the conductor rail can be loaded with the full rated current, since no thermal overload occurs due to the interruptions and no trip of the protective device is caused.

---

## Load values for the different operating modes and operating temperatures (ambient temperature)

---

**S1 Continuous operation** at full rated current, without cool-down phases (no crane application)

<20°C duty cycle = 100%

>20°C application of the correction factors (page 23) and recommended reduction to 80% duty cycle

**S2 Short-term operation** under full rated current, recommended reduction: 80% duty cycle (crane usually 20-30% duty cycle)

**S4 Intermittent operation** at full rated current, recommended reduction 80% of the duty cycle (crane usually 20-30% duty cycle)

**S9** (non-periodic load and speed curve) Load with rated current up to the equivalent of 80% duty cycle

The following generally applies: With higher ambient temperatures, the convection of the conductor strip, conductor rail and protective device decreases, resulting in a reduction of the rated current (see table of correction factors on page 23). The limiting component is usually the current collector. With Xline, this can be operated with 34 A 100% duty cycle.

---

## Calculation of the voltage drop

---

The maximum expected voltage drop is calculated in order to avoid start-up and malfunction due to undervoltage. The value of the voltage drop should not exceed 3-5% in order to have sufficient reserves for the entire wiring path from the supply to the load.

The calculation is based on the voltage applied (AC or DC voltage, the length, the starting current and the resistance or impedance specifications).

The distance between the feed-in point of the conductor rail and the furthest position during operation is used as the length.

Note: If several cranes are supplied, the simultaneity factor and the position of each individual crane must be considered or evaluated using an auxiliary table. In this case, not all consumers are included in the calculation and the simultaneity is therefore taken into account.

### Voltage drop on the conductor rail

For three-phase current  $\Delta U = \sqrt{3} \cdot I \cdot I_A \cdot Z$

For alternating current  $\Delta U = 2 \cdot I \cdot I_A \cdot Z$

For direct current  $\Delta U = 2 \cdot I \cdot I_A \cdot R$

Z = impedance [Ω/km]

R = Resistance [Ω/km]

I = Feed-in length [km]

I<sub>A</sub> = Starting current of the system [A]

### Resistance and impedance values $I_A = 1,2 \cdot I_{nenn}$

Type		
Rated current	63 A	80 A
Cross section [mm <sup>2</sup> ]	10	16
Resistance [Ω/m]	0,0019	0,0011
Impedance up to 60 Hz	0,002	0,0012

#### Note

The formula is based on the calculation of the starting current with inverter operation with a starting factor of 1.2 x the rated current of the loads. Inverter operation is the most economical and most frequently selected variant today.

# Detailed technical design and application information

## Current load and protection

In the standard crane range, the fuse protection and power requirement are specified and used as input values for the conductor rail. In most cases, the maximum cable length between the feed point and the hoist is also specified. This information refers to multi-core cables, e.g. as festoon cables. Higher current and power paths can be achieved with conductor rails due to better heat dissipation.

Unless otherwise stated, the nominal values of the components refer to a 100% duty cycle and an ambient temperature of 20°C. With a lower duty cycle, as in the standard crane range of 20 to 60%, the conductor rail can be loaded with higher currents. At higher ambient temperatures, the current load must be reduced.

### Temperature correction factor $f_T$

Ambient temperature °C	20 °C	35 °C	40 °C	45 °C	50 °C	55 °C	60 °C
Correction factor $f_T$ standard insulation	1	0.97	0.93	0.89	0.84	0.77	0.71

### Permissible continuous current of the conductor rail

$$I_{Dzul.UT} = I_{zul.} \cdot f_T [A] \text{ with } I_{Dzul.UT} > I_{DA}$$

$I_{Dzul.UT}$  = Permissible continuous current at ambient temperature  
 $I_{zul.}$  = Permissible continuous current at 20°C (catalog value) [A]  
 $f_T$  = Temperature correction factor

The conductor rail is fused on the power feed side for the rated current of the conductor rail or less for smaller loads. Behind the current collector, the load is fused according to the maximum current load of the current collector, the cable or the cable cross-section at the load.

## Use of the conductor rail

The conductor rail components are designed for use in bridges and hoists, preferably indoors with a straight crane runway. They are installed horizontally with the current collector engaging from below using hanger clamps.

## Cable connection and cable routing of the current collector

The current collector has an integrated terminal box with cable glands for strain relief of the customer's connecting cable. The cable must be routed in a loop. When designing the loop, it must be ensured

- that the loop cannot get caught when the crane moves
- the cable does not subject the current collector to lateral forces
- strain relief is provided by the cable gland
- the current collector is pulled with the chain towing arm and not with the cable

## Environmental influences and protection class

Like all conductor rail systems available on the market, the components have protection class IP2X and can therefore be used anywhere where this protection class is sufficient.

Use in explosion-protected areas or in applications that prohibit the use of conductor rails as an open energy supply system is not permitted.

In contrast to a cable, enclosed conductor rails are not hermetically sealed and are therefore restricted when exposed to weathering, increased dust, suspended matter or gases that affect their function and safety.

## Conductor rail and PE function

In most countries, earthing via the runway is no longer permitted for crane systems. The protective conductor must be established via a separate protective conductor pole via the conductor rail. In the risk assessment, the loss of the protective function, e.g. due to damage to the consumer, must be taken into account and the function ensured.

This can be ensured by monitoring the protective conductor circuit or the redundant design of the current collector. The current collector 0843 has a redundant protective conductor design, which means that the 2nd current collector trolley that would otherwise be required can be omitted.

# www.conductix.com

## **Conductix-Wampfler**

has just one critical mission:

To provide you with energy and data transmission systems that will keep your operations up and running 24/7/365.

To contact your nearest sales office, please refer to:

**[www.conductix.contact](http://www.conductix.contact)**

