

Insulated Conductor Rail

SinglePowerLine Program 0813

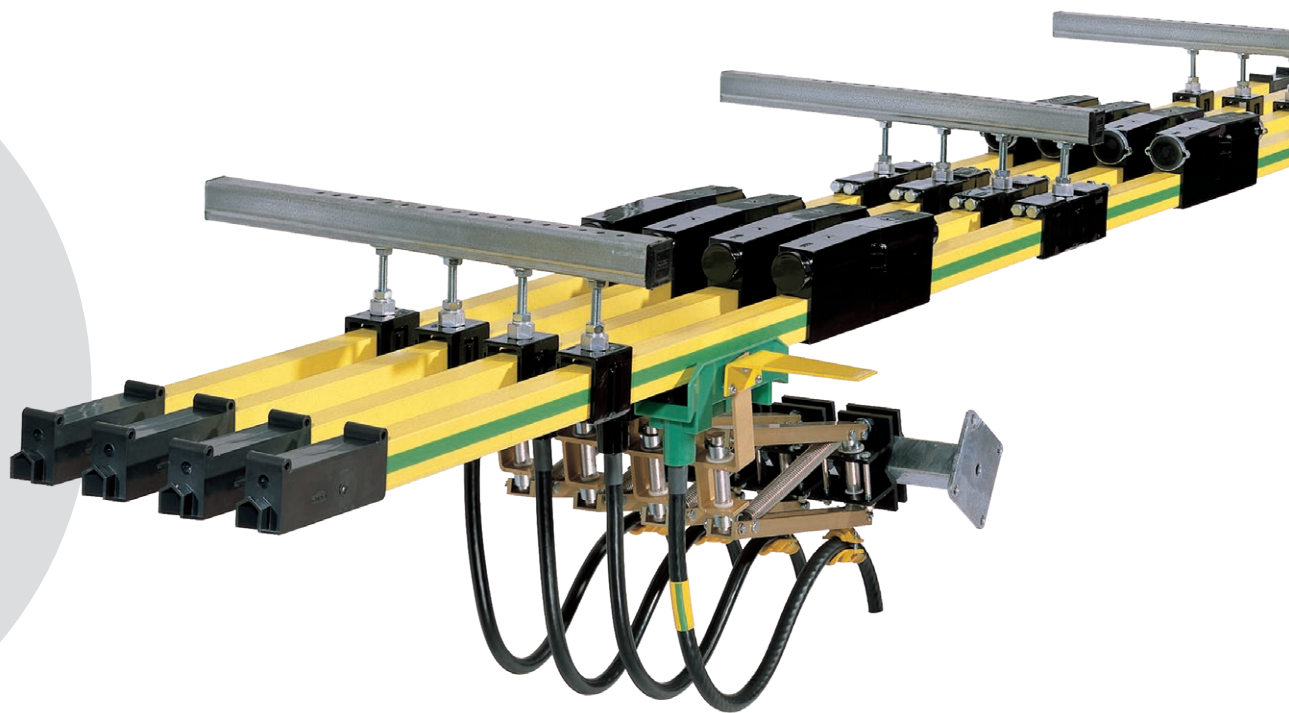

CONDUCTIX
wampfler

Table of Contents

System Description	5
Technical Data	6
General Instructions	7
System Structure	8
Components and their use	8
Insulated Conductor Rails	9
Comparison of different Conductor Rail materials	10
Clamps and Connectors	11
Hanger Clamps	11
Rail Connectors	12
Power Feed Connectors	12
Anchor Clamps	13
End Caps	13
Tubular Cable Lugs for Power Feed Line	13
Air Gaps	14
Expansion Units	15
Pickup Guides for Intersections	17
Current Collectors	18
Parallel Arm Type Current Collectors	18
Parallel Arm Type Double Current Collectors	19
Installation Instructions and Assembly Help for Current Collectors	20
Dimensioning and Layout of Conductor Rail Systems	22
System Layout	25
Layout Examples	27
Mounting Accessories	28
Support Arms 40 × 40 × 2.5 - perforated	28
Permissible Load for Support Arms	28
Holders for Support Arm 40 × 40 × 2.5 for Screw Mounting with 2-holed Connector Plate	29
Holders for Support Arm 40 × 40 × 2.5	29
Girder Clips, Clamping Thickness 4 - 20 mm	30
Girder Clips, Clamping Thickness 18 - 36 mm	30
Girder Clips, non-twistable, Clamping Thickness 6 - 25 mm	30
Towing Arms	31
End Caps	31
Insulators	31
Terminal Boxes for Power Feed with Fittings, Glands and Accessories	32
Terminal Boxes for Joints with Fittings, Glands and Accessories	32
Tools and Accessories	32
Mounting Comb 081046	32
Grounding and Short-Circuiting Device	33
Contact Grease for Connection Points	33
Replacement Parts	34
Replacement Sliding Contacts for Current Collector Heads	34
Replacement Parts for Current Collectors	34

System Description

The SinglePowerLine 0813 conductor rail system is used as a standard product in the area of bridge, portal and process cranes, but also in a wide variety of other applications such as amusement rides and people movers. For over 35 years, it is a specified, reliable and approved product in these applications.

As an insulated single-pole safety conductor rail, the contact-protected system meets requirements for conductor rails according to European (CE) and current international standards and is listed and approved for use in the United States and Canada by Underwriter Laboratories UL, CSA as well as GOST-R.

With different insulation materials, applications can be covered with conductor temperatures of up to 115°C. This corresponds to a permanent ambient temperature of 85°C at 100% duty cycle under continuous load. The conductor rail can temporarily withstand up to 125°C.

For conductor materials, copper, and aluminum in sea-water resistant

alloy with stainless steel tread are available, as well our special material Copper**ECO III**. Copper**ECO III** offers you an alternative between copper and aluminum-stainless steel with good corrosion protection for high current requirements, even during standstill operation.

With the partial expansion compensation system (compensation for thermal expansion in every rail part), systems up to 200 m in length can be implemented without the use of additional expansion elements.¹⁾

The safe, refined connector system and clip-on rail holders, in combination with optional mounting brackets, permit fast, economical assembly.

With the SinglePowerLine 0813 system and the 0813 product line extension for higher power ranges, Conductix-Wampfler offers a reliable, proven and robust solution for your application. Present around the world, our representatives and sales partners are glad to be at your side from planning to implementation and service.

The plastic insulation of the conductor rails is colored warning yellow in accordance with general marking regulations, and the PE conductor rail components are green and yellow (continuous green colour strips). Other colours are available upon request (note minimum order quantities).

Safety conductor rail with a finger-safe design. Testing of contact protection with IEC / UL / NEMA jointed test fingers (12 mm foreign bodies).

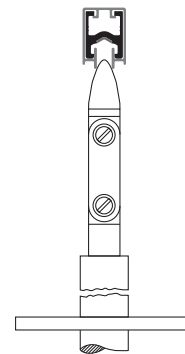









System advantages:

- available in different conductor materials
- finger-safe design
- used around the world
- modular, expandable system
- self-extinguishing insulation compliant with UL-94 standard
- Yellow safety-color
- Designed for 100% duty cycle according to European standards
- Self-aligning hanger clamps
- Seawater-resistant
- Special seamless and corrosion-resistant process for connection of aluminum rails and stainless steel contact surfaces

¹⁾ Take arrangement and ambient temperature into consideration.

Technical Data

Conductor Rails	Aluminum with Stainless Steel Contact Insert			Copper ^{ECO III}			Copper		
Type	081313	081314	081319	08131C	08131D	08131I	081315	081316	081317
Current Load [A]									
At 100% duty cycle and 35 °C (rated value)	500	800	1000	500	800	1000	500	800	1250
At 60% duty cycle and 20 °C	510	810	1050	510	810	1050	520	880	1400
Rated voltage [V]	690 (UL 600 V) – min. 24 V / 1A (minimum load)								
Protection type	Vertical insertion of current collector: IP23 (DIN EN 60529, VDE 0470-1); horizontal insertion of current collector: IP21								
Safety level	Finger-safe design (collector: finger-safe entry only)								
Installation orientation	Horizontal with collector entry on bottom side; collector entry sideways optional, for indoor use only								
Application area	Crane construction, container-stacking cranes, steel mill cranes, process cranes and similar applications								
Environment	Indoors and outdoors (see protection class)								
Rated suspension spacing [m]	2.5 (98 Inches) typically 2.4 bis 2.5								
Rail length [mm]	5000 (196.9 Inches) (rated dimensions at 20 °C / tolerance ± 3 mm)								
System length [m]	unlimited								
Exterior dimensions [mm]	32 x 42 (rail cross section)								
Rated rail spacing [mm]	80 (3.15 Inches) (minimum spacing can be extended as needed)								
Travel speed [m/min]	600 m/min (straight segments without interruptions, such as Pickup Guides, Air Gaps, etc.)								
Expansion / expansion connectors	Compensation up to 200 m (565 feet) in system length, above 200 m the use of expansion elements is necessary								
Permitted ambient temperature ¹⁾	-15 °C to 55 °C (85 °C in heat-resistant design / PPE + SB) [deeper temperatures on request]								
Maximum conductor temperature	+85 °C (115 °C in heat-resistant design / PPE + SB, temporarily 125 °C)								
Storage temperature	-30 °C to +40 °C (dry storage; avoid condensation)								
Conductor materials	Depending on type: electrolytic copper, seawater-resistant aluminum with stainless steel contact surfaces, or our new hybrid material Copper ^{ECO III}								
Rail insulation	Stabilized hard PVC (standard material) and PPE + SB (heat-resistant design for interior use)								
Overvoltage category	III (EN 60664-1-2007/VDE0110-1)								
Installation- / Mounting tolerance	Distance between isolation items and steel structure : Min. 10 mm (also see system sketch)								
Flammability / fire safety	Meets requirements for insulation materials in UL 94 V-1; Flame retardant and self-extinguishing (IEC 60695-11-10), halogen-free PPE-SB								
Local approvals	UL / CSA / GOST-R								
Coloration	Rail insulation in safety warning colour RAL 1018 Zinc yellow or RAL 1021 Rape yellow in heat-resistant design								

Program 0813:

Use the power supply of cranes, construction of larger slip ring assemblies, transfer carriages, cable trays outside the public accessible area, out of arm's indoor and external applications (IP2x) mounted.

- Current collectors sideways or from below
- Mounting position of the rails horizontally (not vertically / vertical application or consultation hold)
- Additional equipment needed for outdoor use, e.g. insulators, overhead covers, rail-heating elements, must be considered
- Touching the current collectors is prevented by appropriate measures on the plant side. Contact protection class IP23 (with vertical current collector insertion) or IP21 (with horizontal current collector insertion)

Relevant standards	
DIN EN 60664-1, VDE 0110-1:2008-1	Insulation coordination for electrical equipment in low-voltage installations - Part 1: Principles, requirements and testing (IEC 60664-1:2007); German edition EN 60664-1:2007
DIN EN 60204-1, 60204-32, VDE 0113-1:2007-06	Safety of machines - electrical equipment of machines - Part 1: General requirements (IEC 60204 - 1:2005, modified); German edition EN 60204-1:2006
DIN EN 60529, VDE 0470-1:2000-09	Protection classes using housings (IP code) (IEC 60529:1989 + A1:1999); German edition EN 60529:1991 A1:2000

Subject to technical modifications

¹⁾ At temperatures below -10 °C, the mechanical stress due to physical limitation of the breaking strength must be limited.

²⁾ At low temperatures, temperature flexible cables should be used.

General Instructions

Application Area

This product is intended for the supply of mobile consumers in the rated current range up to 1250 A and voltages up to 690 V / 1000 V. Target applications are hoist/ crane systems, container stacking cranes, steel mill- or STS-cranes and similar applications with one or more mobile units.

The insulation materials are resistant to many ingredients used in the industrial environment, depending on concentration and exposure time. All metal parts are available in copper or seawater-resistant aluminum depending on construction type, and should be evaluated in accordance with the general suitability of these basic materials.

Before using in critical environmental conditions such as galvanizing plants, pickling plants, compost works and locations with high concentrations of chemicals (e.g. solvents, aromatics, benzols, etc.), please contact us.

Layout

There are several decisive factors in the selection and layout of conductor rails. One main characteristic is the current load that actually occurs (total current to be expected during operation – not to be confused with the installed power or the resulting maximum current) and the resistance values of the system. Here we look at the longest segment between the power feed and the position of the consumer during start-up. The criterion in question is the resulting voltage drop. Depending on the conductor material and cross section, different losses can result for the same length and current. A conductor rail is properly dimensioned from the point of view of voltage drop when the drop lies within the permitted tolerance range, generally 2-5% and at most 10% including the connection feed cable.

Conductor rails are classified by their rated current. This corresponds to the maximum continuous current for the conductor rail and is based on the standard parameters of 35 °C ambient temperature and 100% duty cycle (according to IEC \geq 10 min ON). If the duty cycle or ambient temperature is lower, higher currents can be transmitted. Further information about the layout

of conductor rails and corrections to rated current specifications is listed starting on page 22.

Electrical Safety

Insulated SinglePowerLine 0813 conductor rails are designed according to applicable international standards and guidelines, meet today's requirements for the safety of a conductor rail and have contact protection compliant with DIN EN 60529 (protection class IP 23). They meet the general requirements for classification and evaluation defined in DIN EN 60204 part 32 - Electrical requirements for hoisting machines.

Conductor rails and rail components have a high level of safety. With contact protection, direct contact between body parts and electrically conducting parts is prevented (finger protection with DIN VDE and EN / NEMA test fingers / 12 mm foreign bodies). The current collectors are also designed finger-safe when engaged in the rails, but in areas where they leave the rails, such as intersections and switch points, they must be additionally protected using power switches, covers or distance. Installations with voltages over 25 V DC and 60 V AC in publically accessible areas must be secured by covers, installation away from accessible areas or other suitable means.

Installations in which the insulation characteristics may be reduced by conductive dust or moisture must be installed away from access by people and be marked as high-voltage electrical equipment with warning signs. In areas with high operating voltage ($>$ 690 V) and installations in a highly contaminated environment with conductive dust or moisture, insulators must be used.

The single-pole system can be built with any number of poles and extended in a modular manner. Components for the protective conductor are marked in green or green/yellow and may not be used as phase components. Using installed parts and position coding, it is impossible to engage the PE current collector into a phase pole, or to mix phases. We recommend laying out the PE contact redundantly with two current collectors.

Mechanical Safety

Please note that the layout of conductor rails and current collectors between fixed and moving system parts must maintain a safety spacing of at least 0.5 m to avoid crushing risks, or other safety measures must be taken to prevent this risk.

In exposed installation situations, for example over traffic ways, please ask for details.

Use of Conductor Rails

The conductor rails of Program 0813 meet current standards and guidelines for the intended use of the components. For installation into the final product, the specifications valid for this product must be taken into consideration and you must proceed in accordance with the Machine Directive or with the guidelines valid for the place of installation.

Use outdoors

Outdoors, the conductor rail should be protected from environmental influences as much as possible. Use in high humidity and low temperature areas runs the risk of condensation, the formation of frost and ice build-up on the contact surfaces. In installation in this environment, the rails, in particular aluminum rails, must be equipped with an optional rail heater. Our sales department will be glad to assist you with the layout.

Approvals

The conductor rail product line meets the product parameters required for international use for these products and has been developed in accordance with the existing standards and guidelines in the EU and the important industrial markets. In addition to IEC/EN standard compliance, the product line also has local UL/CSA and GOST-R approvals.

System Structure

Components and their use

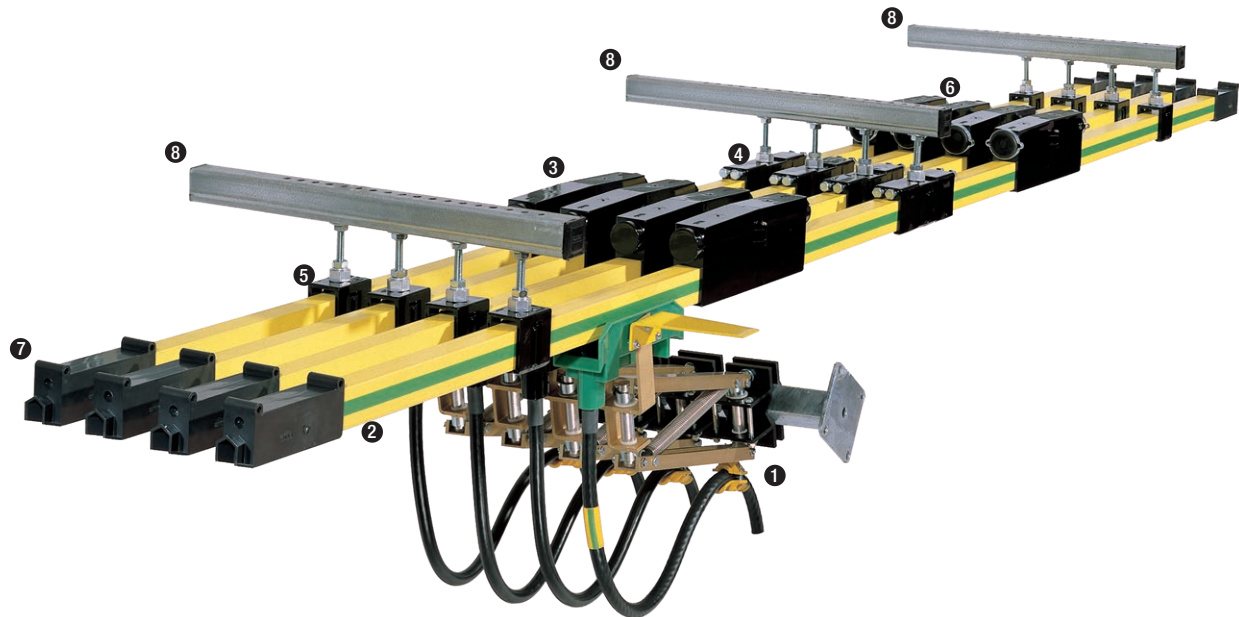

- ❶ **Current Collector:** Connects to the moving part of the system. Maintains positive contact with the rail as it slides.
Available in different sizes as single or dual current collector.
- ❷ **Conductor Rails:** Stable basic body of conductive material with contact-safe insulated profile.
- ❸ **Rail Connectors:** Clamping connectors with insulated cap. Can only be removed with a tool (safety requirement).
- ❹ **Anchor Clamps:** Clamping element for anchoring the system. Forces the rail to expand to either side of the anchor point.
- ❺ **Hanger Clamps:** Freely rotating and thus self-aligning clip-on holder for quick, safe assembly. Mounting height adjustable.
Allows the rail to slide during thermal expansion.
- ❻ **Power Feed Connectors:** Used instead of a rail connector. Universal connection of single strands with outer diameters of up to 17 mm.
- **Expansion Units (not shown):** Changing temperature causes the conductor rail system to expand. To compensate for the expansion in systems over 200 m or systems with multiple fixed points or curves, expansion joints are used.
- ❼ **End Caps:** Rail terminator as protection against accidental contact.
- ❽ **Support Arms**
- **Pickup Guide (not shown):** For areas in which the collector must be driven in or out of the conductor rail system.
- **Air Gap (not shown):** For galvanic isolation, for example of segments during maintenance.

System Advantages

- Robust, tried and tested industrial design
- Safe conductor rail with contact protection (finger-safe design)
- Designed to national and international standards
- High availability
- Expandable
- Partial compensation for thermal expansion
- Simple installation
- Optional safety components / functions
- Rails in safety warning color RAL 1018/1021
- CE-compliant design
- Available with any number of poles

System Structure

Insulated Conductor Rails

The standard product line offers the following conductor materials: electrolytic copper, aluminum, and our new special material Copper**ECO III**.

We therefore offer the ideal solution for every requirement:

- Copper, with its good conductivity and low voltage drop, is the ideal conductor, with restrictions in applications in aggressive or corrosive environments. Used when high amperage is needed, particularly in standstill operation..
- As a budget-priced alternative, aluminum rails with a stainless steel contact surface are also available. Using a special procedure, stainless steel and saltwater-resistant aluminum are firmly joined with no gap, combining the advantages of both materials, that is, good conductivity and low wear, without the disadvantages of other aluminum rails available on the market with stainless steel inserts.
- The portfolio is complemented by our new special material Copper**ECO III**. This innovation offers a significantly improved conductivity compared to aluminum-stainless steel and thus allows high power transmission even when the system is in standstill. Copper**ECO III** is suitable for demanding outdoor environments including saltwater areas. Thereby we can offer an excellent price-performance alternative inbetween copper and aluminum-stainless steel.

The conductor rails consist of the conductive rail body and the protective insulation in a contact-safe design.

As insulation material, PVC is used in standard applications
For higher ambient temperatures halogen-free PPE+SB is used.

Rated length: 5000 mm

Colour: Safety warning RAL 1018 (PVC) / RAL 1021 (PPE+SB)

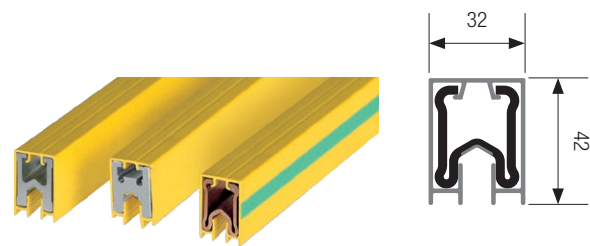

PH = Phase
PE = Potential Earth ("grounding")

NEW

	Aluminum (with stainless steel contact surface)			Copper ECO III			Copper		
Rated current (100% duty cycle)	500 A	800 A	1000 A	500 A	800 A	1000 A	500 A	800 A	1250 A
Rated current (60% duty cycle)	510 A	810 A	1050 A	510 A	810 A	1050 A	520 A	880 A	1400 A
Cu figure	-	-	-	-	-	-	1.6 kg/m	2.86 kg/m	4.76 kg/m
Order number	Standard insulation for ambient temperatures up to +55 °C								
PH	081313-5X11*	081314-5X11*	081319-5X11*	08131C-5x11	08131D-5x11	08131I-5x11	081315-5X11	081316-5X11	081317-5X11*
PE (green color stripes)	081313-5X12*	081314-5X12*	081319-5X12*	08131C-5x12	08131D-5x12	08131I-5x12	081315-5X12	081316-5X12	081317-5X12*

Order number	Insulation for ambient temperatures up to +85 °C								
PH	081313-5X21	081314-5X21	081319-5X21	08131C-5x21	08131D-5x21	08131I-5x21	081315-5X21	081316-5X21	081317-5X21
PE (green color stripes)	081313-5X22	081314-5X22	081319-5X22	08131C-5x22	08131D-5x22	08131I-5x22	081315-5X22	081316-5X22	081317-5X22

Short lengths of 1, 2 and 3 m are available upon request for an additional price for cutting costs

Part No. for semistandard: 0813-__-length X __ (length = 1 for 1 m, 2 for 2 m, and 3 for 3 m), lengths > 6 m on request – example **1m**: 0813XX-1 X 11







* Standard range

Technical Data – Rail Length 5000 mm ± 3 mm

DC resistance [Ω/1000m] 20 °C	0.092	0.071	0.049	0.092	0.071	0.049	0.097	0.054	0.031
DC resistance [Ω/1000m] 35 °C	0.097	0.074	0.051	0.097	0.074	0.051	0.104	0.057	0.033
Impedance [Ω/1000m] 20 °C/50Hz	0.152	0.140	0.134	0.152	0.140	0.134	0.156	0.134	0.126
Impedance [Ω/1000m] 35 °C/50Hz	0.157	0.144	0.137	0.157	0.144	0.137	0.161	0.136	0.127
Weight [kg]	6.92	8.36	10.23	6.92	8.36	10.23	10.36	16.9	25.23

System Structure

Comparison of different Conductor Rail Materials

	Aluminum-Stainless Steel	CopperECO II	Copper
			
Conductivity	Conductivity		
Corrosion resistance	Corrosion resistance		
Price	Price		
Suitable for corrosive environments	✓	✓	–
Application requirements	Standard requirements	High amperage requirements, especially in standstill mode (e.g. crane hoist/AS/RS)	Highest requirements on current carrying capacity
Application example			

Max. Current Carrying Capacity of Current Collectors (250 A) with different rail materials at 30° C ambient temperature

		Aluminum-Stainless Steel	CopperECO II	Copper
a) moving ($v > 10$ m/min)	Current carrying capacity per current collector	250 A = I_{nom}	250 A = I_{nom}	250 A = I_{nom}
b) brief standstill	Max. duration t_s of current carrying capacity during brief standstill *	5 minutes	15 minutes	(no limit)
	Current carrying capacity per current collector	125 A = 50% I_{nom}	250 A = I_{nom}	250 A = I_{nom}
c) standstill for a longer period ($t > t_s$)	Current carrying capacity per current collector	75 A = 30% I_{nom}	200 A = 80% I_{nom}	250 A = I_{nom}

* thereafter moving the current collector by at least 1 m / cooling off for at least the same duration as previous current load

Hanger Clamps

Hanger Clamps

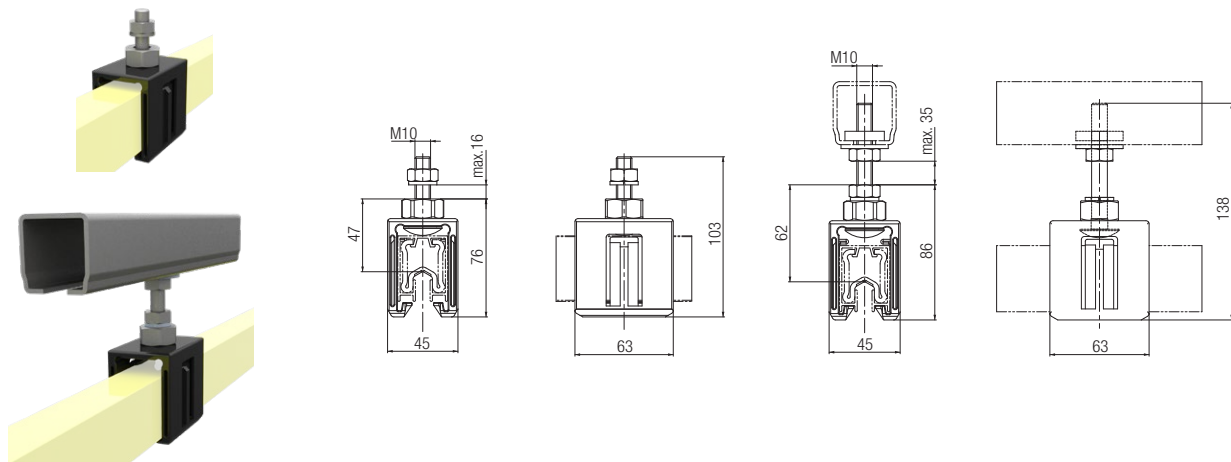

Part No.	Designation	Weight [kg]
081341-01*	Hanger Clamp galvanized with hex nut	0.115
081343-01*	Hanger Clamp galvanized with square nut	0.185
081341-02*	Hanger Clamp in stainless steel with hex nut	0.115
081343-02*	Hanger Clamp in stainless steel with square nut	0.185

* Standard range

Hanger Clamps with Insulators

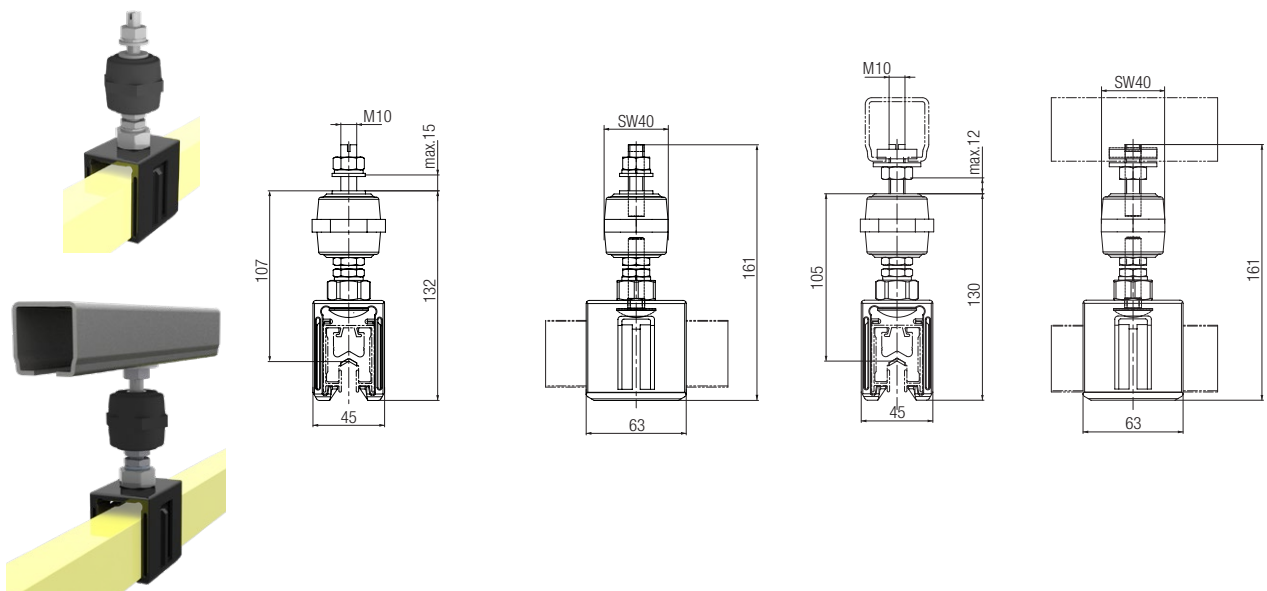

Suspension is carried out using freely swivelling clip-on Hanger Clamps that are self-aligning and permit low-friction slipping in case of thermal expansion. Hanger Clamps are available with hex nuts or square nuts for the mounting of Support Arms / C-rail (see installation accessories).

Note:

- Rated suspension spacing 2.5 m, typically 2.4 to 2.6 m
- Only for suspended installation
- Max. suspension spacing 2.5 m
- Hole drilled for mounting \varnothing 11 mm
- Hanger in full metal version for heavy duty application on request

Part No.	Designation	Weight [kg]
081341-11	Hanger Clamp galvanized with hex nut	0.210
081343-11*	Hanger Clamp galvanized with square nut	0.280
081341-12	Hanger Clamp in stainless steel with hex nut	0.210
081343-12*	Hanger Clamp in stainless steel with square nut	0.280

* Standard range

Rail Connectors and Power Feed Connectors

Rail Connectors

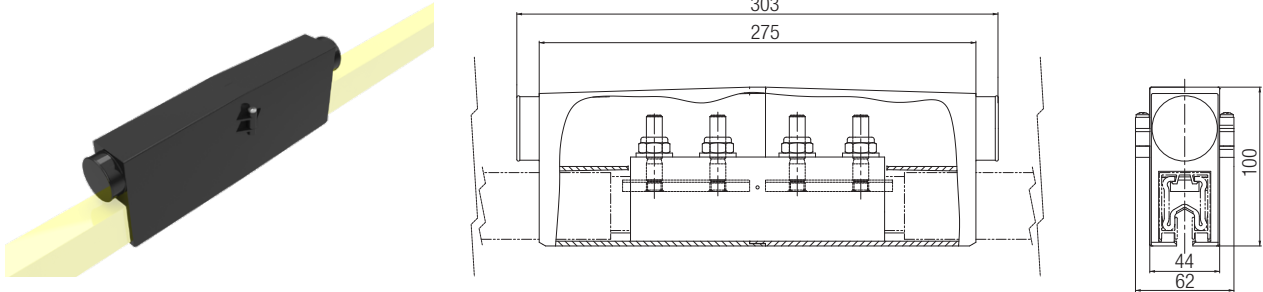

Rails are connected using compact screw connections. The rail connections must have exposed metal on all contact surfaces and be coated with a thin layer of contact grease (part no. 080021) to protect against corrosion. When mounting clamping screws, use a torque wrench to achieve correct tightening torques.

Part No.	Designation		Weight [kg]
081321-1	Connector for copper rails 500/800 A	Galvanized	1.1
081321-2*	Connector for aluminum rails/Copper ECO III rails		1.0
081321-3*	Connector for copper rails 1250 A		1.6
081321-4	Connector for aluminum rails/Copper ECO III rails	Stainless Steel	1.0
081321-5	Connector for copper rails 1250 A		1.6
081321-6	Connector for copper rails 500/800 A		1.1
080021*	Contact grease, one 20 g tube (for approx. 200 connection points)		0.030

* Standard range

Power Feed Connectors

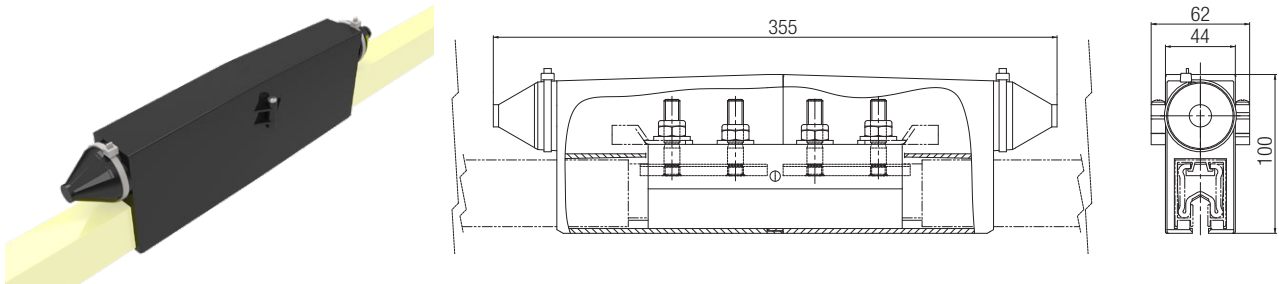

The power feed uses a power connector; these replace the normal rail connectors. Electrical connection is provided using projecting bolts and tubular cable Lugs (cable and cable lugs not included; please order separately).

Note:

- Tightening torque max. 31 Nm
- Max. outer cable diameter 25 mm
- Use contact grease 080021

Part No.	Designation		Weight [kg]
081351-2*	Connector for aluminum rails/Copper ECO III rails	Galvanized	1.0
081351-3*	Power feed connector for copper rails		1.6
081351-4	Connector for aluminum rails/Copper ECO III rails	Stainless Steel	1.0
081351-5	Power feed connector for copper rails		1.6

* Standard range

Tubular Cable Lugs see page 12

Anchor Clamps and End Caps

Anchor Clamps

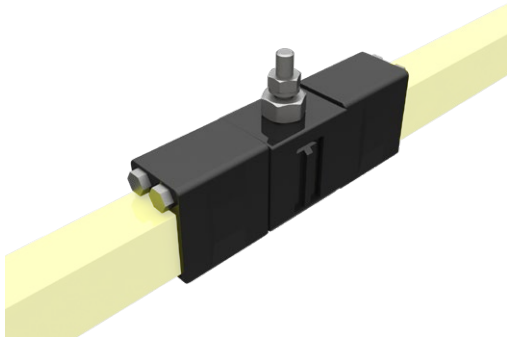

The rails are fixed in one place with Anchor Clamps and can expand freely from that point out. The fixed point is mainly for single feed applications attached close to the power feed or in the center of the conductor rail system. If multiple fixed points are planned, for example at intersections or curves (natural fixed point), the segment between the fixed points must be decoupled using Expansion Units. Clamps are fastened with a clamping cone on the rail insulator.

Part No.	Designation	Weight [kg]
081331-2*	Anchor Clamp	0.122

For each fixed point, order two Anchor Clamps per pole

Not recommended for vertical application

* Standard range

End Caps

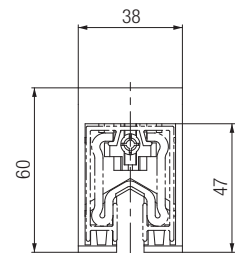
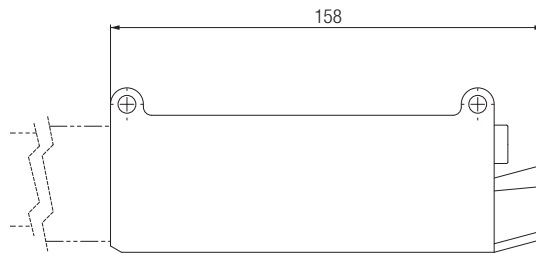
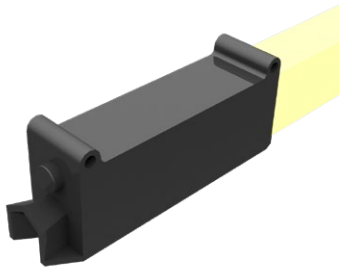

End Caps are used as a rail terminator and contact protection and are fastened to the rails using clamping screws.

Part No.	Designation	Weight [kg]
081371-2*	End Cap – Stainless Steel (DIN parts)	0.136
081373-2*	End Cap for aluminum rails 1000 A (DIN parts)	0.136

* Standard range

Tubular Cable Lug for Power Feed Line

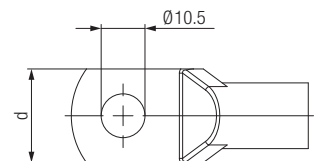
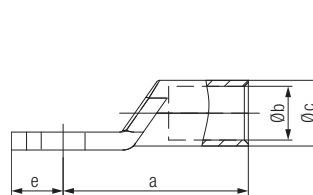

Part No.	Cross section [mm ²]	a [mm]	b [mm]	c [mm]	d [mm]	e [mm]	Weight [kg/1000]
080054-025*	25	34	7,0	10,0	18	12	15,7
080054-035*	35	37	8,5	12,0	19	12	21,3
080054-050*	50	39	10,0	14,0	20	12	30,8
080054-070*	70	44	12,0	16,5	23	12	45,4
080054-095*	95	48	13,5	18,0	26	12	54,0
080054-120*	120	51	15,0	19,5	28	14	65,7
080054-150*	150	56	16,5	21,0	31	14	76,2
080054-185*	185	65	19,0	24,0	35	18	117,5

* Standard range Material: Copper, tin-plated Order lot size 10 pcs. per size

Air Gaps

Air Gaps

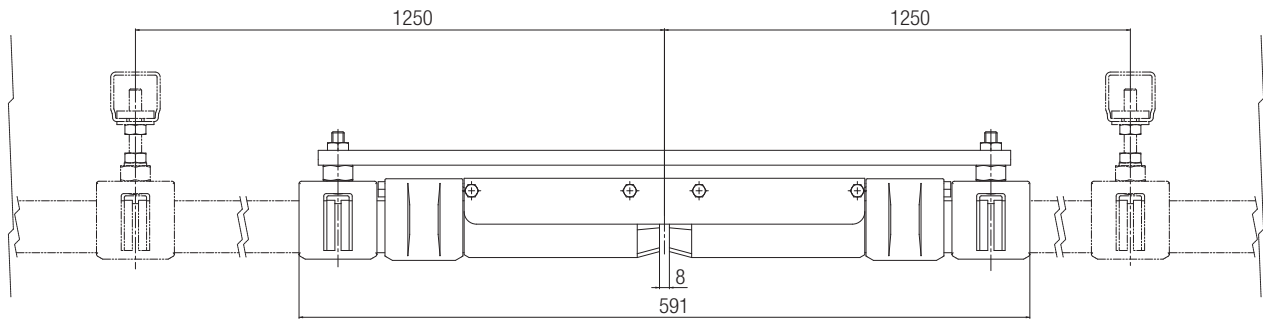

Air Gaps are used for the galvanic isolation of sections, such as maintenance segments that can be supplied with power and turned off separately. For each separation point, two Air Gaps must be mounted at a suitable distance to avoid power carryover through the Current Collectors.

Part No.	Designation	Weight [kg]
081394-2	Air Gap	2.50
081395-2	Air Gap for aluminum rails 1000 A and Copper ECO III rails 1000 A	2.49

Please note: Air Gaps are delivered as an assembly set (not pre-assembled).

Expansion Units

Expansion Units

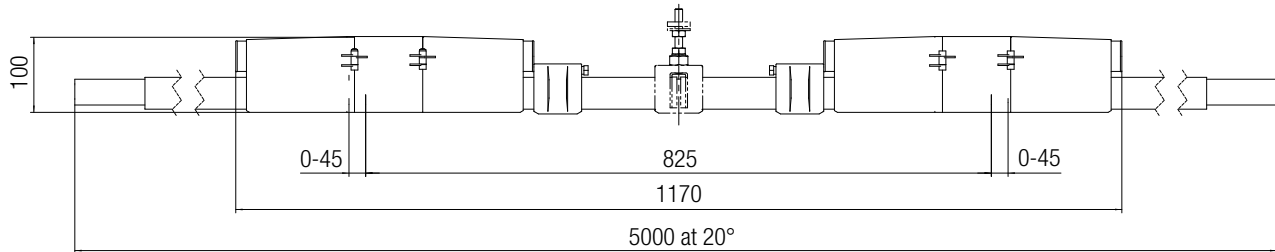

To compensate for changes in length due to temperature for systems > 200 m or segments connected between two fixed points such as Pickup Guides on both ends of the segment, or in curves (natural fixed points), expansion elements are needed to absorb the change in length. The expansion element has two expansion points, each of which can absorb 45 mm of expansion. The expansion elements / expansion unit parts are, like the rails, designed as 5 m standard components.

Note: The middle part between the two expansion segments must be supported using hanger clamps (**not included – order separately**). When using expansion units, the use of dual Current Collectors is recommended.

	Expansion Units Standard variant		Expansion Units Heat-resistant variant		Weight [kg]
	PH (Phase)	PE (Potential Earth)	PH (Phase)	PE (Potential Earth)	
For aluminum rails 500 A	081362-5X2131*	081362-5X2132*	081362-5X2231	081362-5X2232	10.8
For aluminum rails 800 A	081362-5X2141*	081362-5X2142*	081362-5X2241	081362-5X2242	14.5
For aluminum rails 1000 A	081362-5X2181*	081362-5X2182*	081362-5X2281	081362-5X2282	16.5
For CopperECO III 500 A	081362-5X21C1	081362-5X21C2	081362-5X22C1	081362-5X22C2	10.8
For CopperECO III 800 A	081362-5X21D1	081362-5X21D2	081362-5X22D1	081362-5X22D2	15.5
For CopperECO III 1000 A	081362-5X21I1	081362-5X21I2	081362-5X22I1	081362-5X22I2	16.5
For copper rails 500 A	081362-5X2151	081362-5X2152	081362-5X2251	081362-5X2252	13.8
For copper rails 800 A	081362-5X2161	081362-5X2162	081362-5X2261	081362-5X2262	22.5
For copper rails 1250 A	081362-5X2171*	081362-5X2172*	081362-5X2271	081362-5X2272	31.6

Design: Fastening and DIN parts in stainless steel – rated length 5000 mm (16.40 feet). Hanger Clamps in the middle segment not included in scope of delivery – please order separately!

Delivery: completely pre-assembled at the factory. Adjustment of the two expansion gaps according to the table on page 15, depending on temperature values.

* Standard range

Layout notes

Changes in ambient temperature and intrinsic heating cause the conductor rails and the insulation to expand differently. The SinglePowerLine 0813 conductor rail system has a partial thermal expansion system. The difference in thermal expansion between the insulation and the rails is compensated for in each individual rail. For this reason, the insulation profile is specified shorter than the rail and the compensation takes place in the area of the connector caps without influencing the contact guard.

By using self-aligning, rotating Hanger Clamps, the rail line can expand without friction and thus be laid out up to a length of 200 m without additional Expansion Units. If the power feed is in the middle with a fixed point at the power feed, installations of up to 200 m can be laid out without expansion elements by allowing the segment to expand freely to each side for 100 m from the fixed point.

For installations of greater length, multiple fixed points such as Pickup Guides or curves that also have a fixed position due to a fixed point or mechanical attachment, expansion joints must be used to absorb the changes in length.

Pickup Guides and curves are to be considered as fixing points.

Mounting instruction

The distance between insulating caps and steel construction should be at least 10 mm.

Expansion Units

Expansion Units

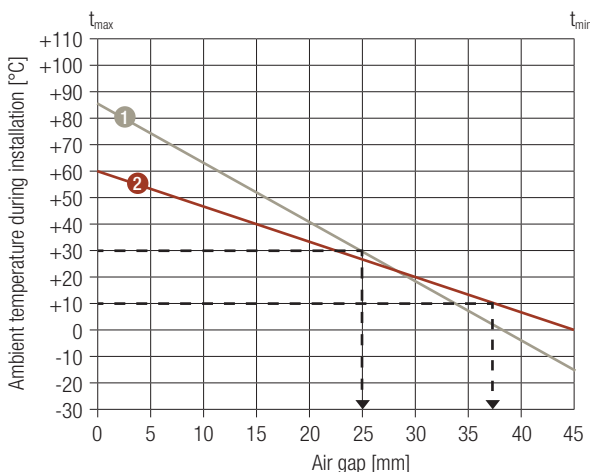

Legend:

t_{min} lowest temperature that occurs in the application
 t_{max} highest possible working temperature in the application

1. Draw a connecting line from t_{min} to t_{max} .
2. Draw the ambient temperature during installation as a horizontal line.
3. Draw a vertical line down from the point of intersection of these two lines, and read off the air gap to be used during installation.

Examples:

1. Temperature range: from -15 °C to +85 °C
 Ambient temperature during installation: +30 °C
 Air Gap: 25 mm
2. Temperature range: from 0 °C bis +60 °C
 Ambient temperature during installation: +10 °C
 Air Gap: 37 mm

Number of Expansion Units for systems over 200 m in length

For rail conductor installations over 200 m in length, Expansion Units must be installed at specific intervals, as shown in Diagram 3. In complicated curves and other special installations, as well as for fixed point arrangements at the end of the system, special intervals must be used. Please contact us.

Number of Expansion Units	1		2		3		4		5		Intermediate length a		
	Al*	Cu	Al*	Cu	Al*	Cu	Al*	Cu	Al*	Cu	Al*	Cu	
	Total length of the conductor rail [m]												
Δt_{ges}	10	400	400	600	600	800	800	1000	1000	1200	1200	200	200
	20	387	400	575	600	762	800	950	1000	1138	1200	187	200
	30	325	376	450	553	575	729	700	905	825	1082	125	176
	40	293	332	387	464	481	597	575	729	669	862	93	132
	50	275	306	350	412	425	517	500	623	575	729	75	106
	60	262	288	325	376	387	464	450	553	512	641	62	88
	70	253	275	307	351	360	427	414	502	468	578	53	75
	80	247	266	294	332	340	398	387	464	434	531	47	66
	90	242	259	283	317	325	376	366	435	408	494	42	59
	100	237	253	275	306	312	359	350	412	387	464	37	53

Al = aluminum, Cu = copper

*expansion of Copper **ECO III** material comparable to Aluminum-stainless steel

$$\Delta t_{ges} = \Delta t_U + \Delta t_{sw}$$

Δt_U = Temperature range of the ambient temperature

Δt_{sw} = Temperature increase due to electric current (electrical thermal load)

Recommended values for Δt_{sw} :

10 °C up to 40% duty cycle

20 °C up to 65% duty cycle

30 °C up to 100% duty cycle

For longer systems than those in the table above, use:

$$\frac{L - 200}{a} = \text{number of Expansion Units}$$

Diagram 3

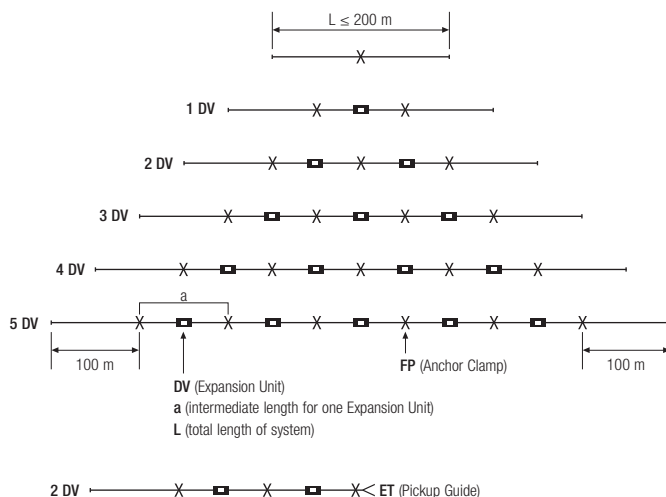

Note: Intersection Pickup Guides and curves are fixed points, so these areas must also be taken into consideration when laying out the system.

Pickup Guides for Intersections

For areas in which the collector must be driven in or out of the conductor rail system, Pickup Guides are used in combination with Current Collectors provided for this purpose. The speed for Pickup Guide entry must not exceed 80 m/min and that Pickup Guides must be considered wearing parts. Installation tolerances must be taken into consideration. Simultaneous alignment gaps with maximum tolerances in the X and Y directions are not permitted.

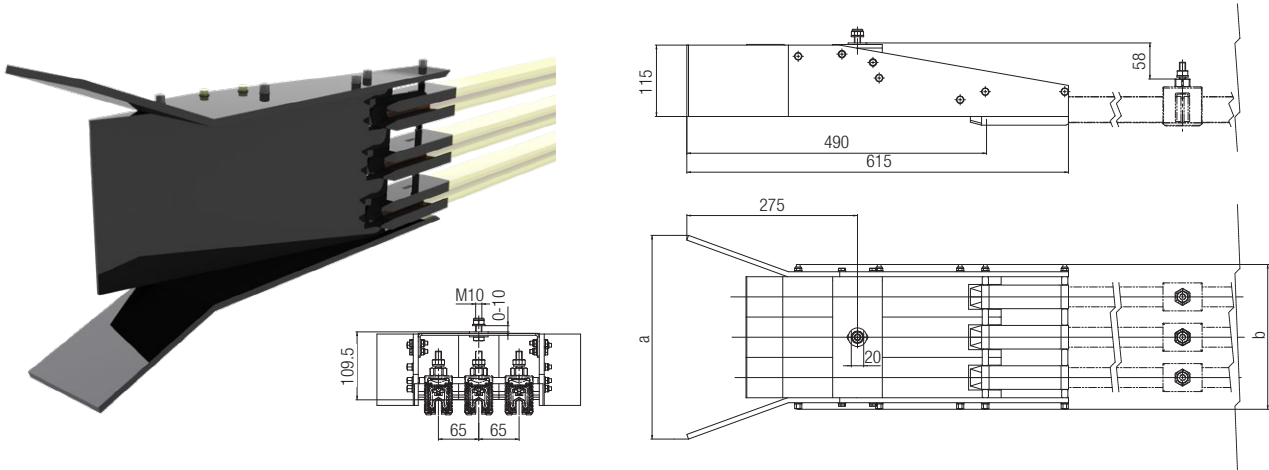

Dimensions [mm]	Number of poles				
	1	2	3	4	5
a	200	265	330	395	460
b	105	170	235	300	365

- The Pickup Guide centers the Current Collector with a maximum lateral and vertical alignment tolerance of ± 25 mm.
- Settings of less than ± 10 mm are recommended.
- In installations with Pickup Guides, a corresponding number of Current Collectors must be available, and mounted in intervals that ensure that just the necessary number of Current Collectors needed for momentary power requirements are in use.

The user must ensure that the Current Collectors between the Pickup Guides are disconnected from power or are protected against accidental contact.

Part No.	Type of fastening elements: stainless steel	Weight [kg]	
081382-12	1-pole Pickup Guide	1.86	
081382-22	2-pole Pickup Guide	2.63	
081382-32	3-pole Pickup Guide	3.40	
081382-42	4-pole Pickup Guide	4.17	
081382-52	5-pole Pickup Guide	4.94	
081383-12	for Aluminum rails / CopperECO III rails 1000 A	1-pole Pickup Guide	1.86
081383-22		2-pole Pickup Guide	2.63
081383-32		3-pole Pickup Guide	3.40
081383-42		4-pole Pickup Guide	4.17
081383-52		5-pole Pickup Guide	4.94

Installation note

The middle distance between two conductors is 80 mm. This is reduced to 65 mm using the last Hanger Clamp before the Pickup Guide in order to ensure that the Current Collector enters the Pickup Guide precisely. The Pickup Guide is delivered complete with End Caps. The End Caps are pushed onto the rails with a soft-head hammer until they hit the end stops. The clamping screws are then tightened firmly.

Hanger Clamp spacing for installations with Pickup Guides

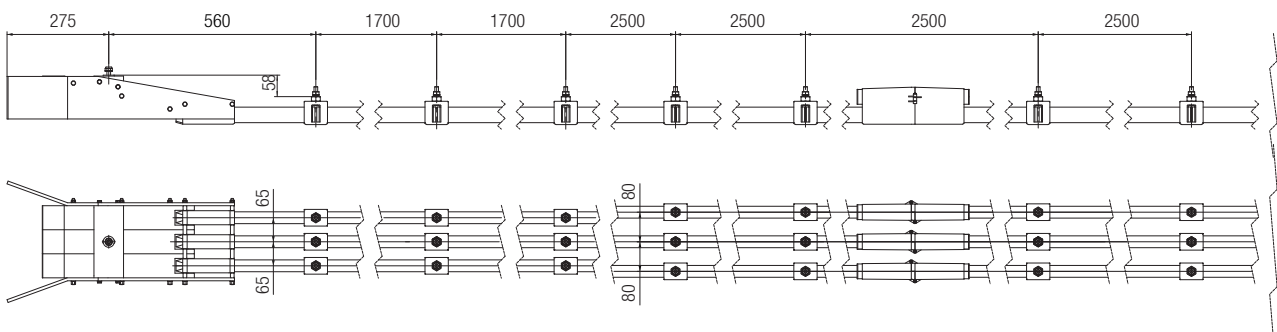

Please note also the instructions for mounting the PE Current Collector for installations with Pickup Guides.

Current Collectors

Current Collectors 250 A

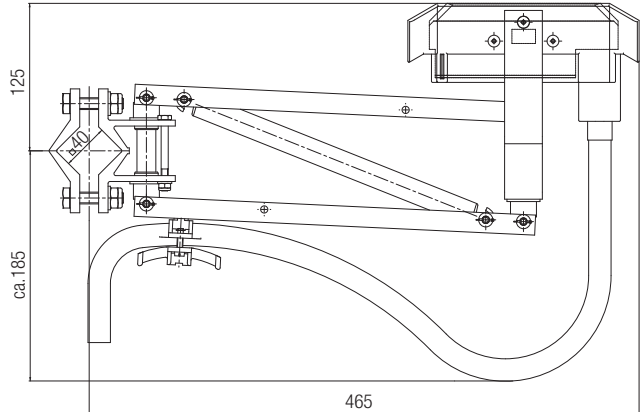
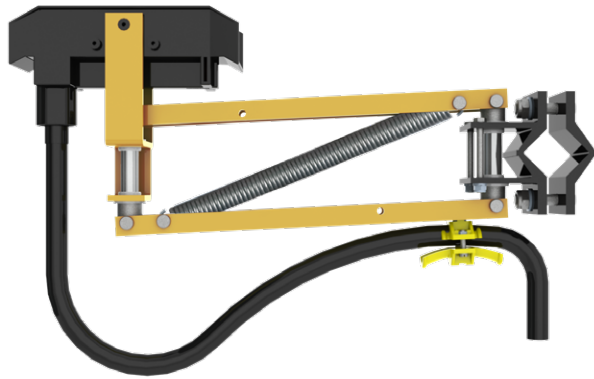

Technical data

Max. current capacity	250 A (30 °C / 100% ED) [for aluminum rails in standstill mode at 100% duty cycle: 125 A]
Max. travel speed	600 m/min; higher travel speeds upon request
Pressing force	28 N
Lateral deviation	± 100 mm
Working stroke in insertion direction	± 40 mm
Connection cable	70 mm ² , 1.5 m long, high-flexibility; longer connection cable available upon request
Distance between the extension arm axis and contact surface of the rail	125 mm (important functional dimension)
Temperature range cable	- 15 °C up to + 55 °C (Ambient)

Max. Current depending used cable type, ambient temperature and cable arrangement.

Installation note

The user must ensure that the Current Collector's center line is exactly aligned with the center line of the conductor rail during installation, and that the specified installation spacing between the extension arm axis and the contact surface of the rail is being observed (see installation examples on page 27).

The connection cables must be highly flexible to ensure free movement of the Current Collectors and be secured with the cable binder on the Current Collector in such a way that no tension or torsion forces are transmitted to the Current Collector head.

Designation	Part No.				Weight [kg]
	PH (Phase)		PE (Potential Earth)		
	Fastening elements galvanized	Fastening elements in stainless steel	Fastening elements galvanized	Fastening elements in stainless steel	
Current collector 250 A with vertical insertion	081301-01*	081301-11*	081301-02*	081301-12*	2.800
Current collector 250 A with horizontal insertion	081303-01	081303-11	081303-02	081303-12	3.000
Current collector 250 A with vertical insertion for intersection ¹⁾ with Pickup Guides 081382	081304-01	081304-11	081304-02	081304-12	3.225

¹⁾ Current Collectors for intersections are used if the path of the conductor rail installation is interrupted by branch tracks, crossing beams, etc. These Current Collectors are equipped with a middle centering device and are used with Pickup Guides.

²⁾ It is recommended to carry out PE current collector always redundant.

* Standard range

(SAP KONFIG 08130X-PXL)

Installation Examples see page 27

Current Collectors

Dual Current Collectors 500 A

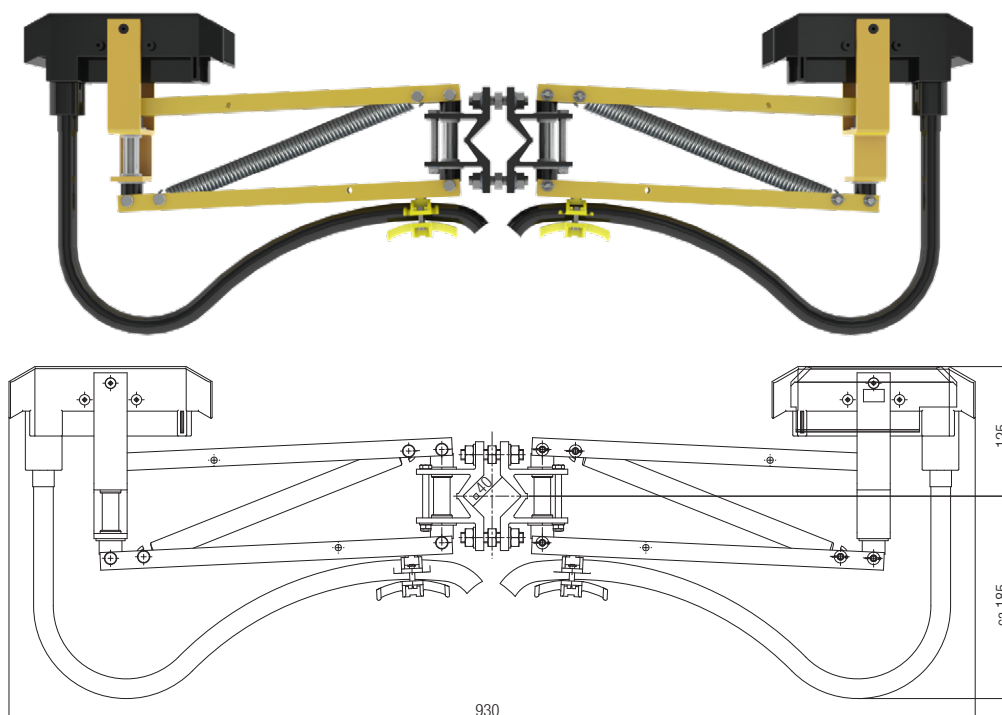

Technical data

Max. current capacity	500 A (2 x 250 A 30 °C / 100% duty cycle), [for aluminum rails in standstill mode at 100% duty cycle: 250 A]
Max. travel speed	600 m/min; higher travel speeds upon request
Pressing force	2 x 28 N
Lateral deviation	± 100 mm
Working stroke in insertion direction	± 40 mm
Connection cable	70 mm ² , 1.5 m long, high-flexibility; longer connection cable available upon request
Distance between the extension arm axis and contact surface of the rail	125 mm (important functional dimension)
Temperature range cable	- 15 °C up to + 55 °C (Ambient)

Max. Current depending used cable type, ambient temperature and cable arrangement.

Installation note

The user must ensure that the Current Collector's center line is exactly aligned with the center line of the conductor rail during installation, and that the specified installation spacing between the extension arm axis and the contact surface of the rail is being observed (see installation examples on page 27).

The connection cables must be highly flexible to ensure free movement of the Current Collectors and be secured with the cable binder on the Current Collector in such a way that no tension or torsion forces are transmitted to the Current Collector head.

It is recommended to carry out PE current collector always redundant.

Designation	Part No.				Weight [kg]
	PH (Phase)		PE (Potential Earth)		
	Fastening elements galvanized	Fastening elements in stainless steel	Fastening elements galvanized	Fastening elements in stainless steel	
Current collector 250 A with vertical insertion	081301-2X01*	081301-2X11*	081301-2X02*	081301-2X12*	5.700
Current collector 250 A with horizontal insertion	081303-2X01	081303-2X11	081303-2 x 02	081303-2X12	6.100
Current collector 250 A with vertical insertion for intersection ¹⁾ with Pickup Guides 081382	081304-2X01	081304-2X11	081304-2X02	081304-2X12	6.550

¹⁾ Current Collectors for intersections are used if the path of the conductor rail installation is interrupted by branch tracks, crossing beams, etc. These Current Collectors are equipped with a middle centering device and are used with Pickup Guides.

* Standard range

Current Collectors – Installation Instructions

Installation of the PE conductor Current Collector for installations without Pickup Guides

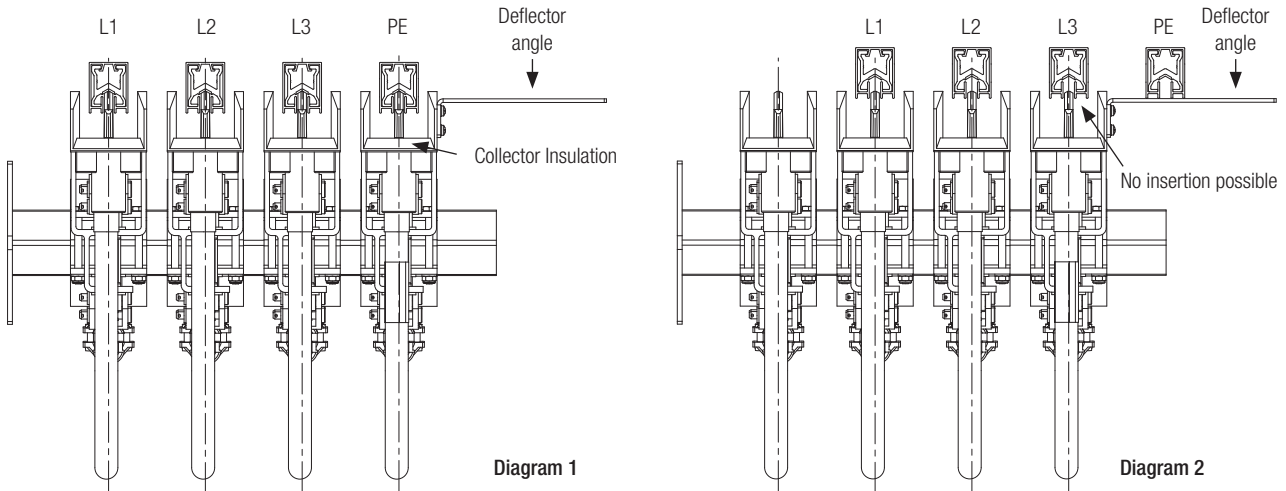

Non-interchangeability of PE (Potential Earth) conductor Current Collectors

To comply with safety standards, Current Collectors for PE rails must be designed in such a way that they are not easily interchangeable with other Current Collectors. When determining the position of the PE conductor, you must take into consideration that the standard PE conductor Current Collector (with deflector angle) can only be mounted on the outside, since the deflector angle is fastened onto the exposed side of the PE Conductor Collector Insulation. The deflector angle ensures that the PE conductor Current Collector can never come in contact with a phase line (see Diagram 2).

Installation of the PE conductor Current Collector for installations with Pickup Guides

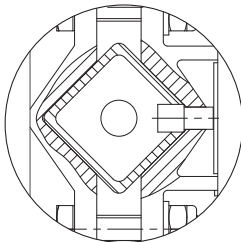

In installations with intersections, it is impossible to move the standard PE conductor Current Collector (with deflector angle) through the Pickup Guide. Thus the PE conductor Current Collector is used for intersections whose holders are equipped with a bolt for the Towing Arm. This fixes the position of the PE conductor Current Collector by being inserted into a hole drilled into the Towing Arm using the Drilling Jig listed below.

This ensures that the PE conductor Current Collector can only be mounted in the place provided for it.

Drilling Jig 08-W100-0223

To comply with regulations and guidelines, installations with Pickup Guides must have a hole drilled into the Towing Arm 020197 using Drilling Jig 08-W100-0223, which is then used to hold the bolt on the PE conductor Current Collector.

Installation note:

The phase Current Collectors needed are lined up on the preassembled Towing Arm 020197 and adjusted to the conductor rails. The next-to-outside phase Current Collector is used as a stop for the Drilling Jig. The Drilling Jig must be attached so that the drill sleeves point outwards – see illustration below. In this position, the mounting spacing is 80 mm.

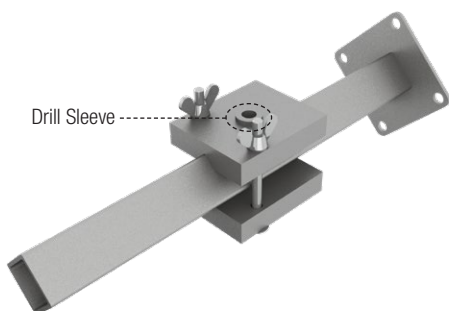

Designation	Part No.	Weight [kg]
Drilling Jig	08-W100-0223	0.700



Dimensioning and Layout of Conductor Rail System

The dimensioning and layout of a conductor rail system is done as follows:

- A: Determine the load current
- B: Select the rail type
- C: Check the voltage drop for the selected rail type
- D: Check of ambient conditions
- E: Select accessories and Current Collectors

A. Determining the load current (total rated current I_{NG})

To determine the total expected load current, individual currents of the highest draw consumers that can operate simultaneously are added up. If the entire installed power is summed, the rail capacity will be over-specified. To avoid overdimensioning, the individual currents are evaluated for simultaneity. To optimize the system, it is always wise to consider individual consumers that cannot be operated simultaneously (e.g. a crane's slewing gear can only be operated when the crane trolley is stopped), and then only the consumer (the slewing gear or the trolley) with the higher current consumption is used.

If multiple units are installed on a single track, for example three cranes on one crane track, the probability of simultaneous operation in the same load should be used to calculate the current. In practice, the following simple table has proved useful in calculating the total rated current I_{NG} for multiple consumers:

Number of cranes	I_N of the most powerful motor of all the cranes I_N^*	I_N of the second most powerful motor of all the cranes I_N^*	I_N of the third most powerful motor of all the cranes I_N^*	I_N of the fourth most powerful motor of all the cranes I_N^*
1	×	×		
2	×	×	×	
3	×	×	×	
4	×	×	×	×
5	×	×	×	×
According to work with 2 cranes	×	×	×	×

* = For dual drives, use $2 \cdot I_N$

B. Rail current capacity depends on duty cycle and ambient temperature

The specified rated currents for the conductor rail are based on the definitions in European standards and are relative to an ambient temperature of 35 °C and a duty cycle (DC) of 100%. If the duty cycle is shorter, such as might be the case for a crane with finite movement, the rail can conduct higher current than the rated current.

Adjusting the rail rated current for shorter duty cycles

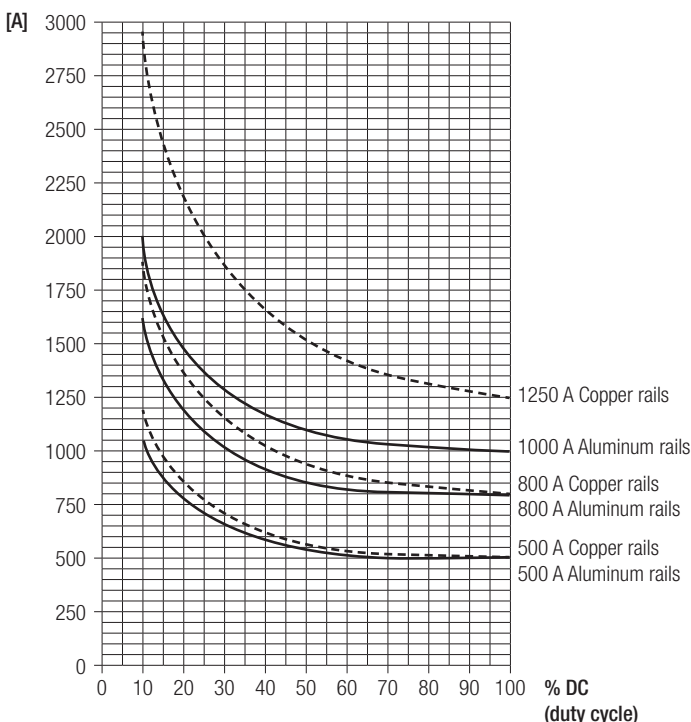

The load current of the conductor rail can be increased for shorter duty cycles.

Note: When comparing the rated currents of rails from different manufacturers, always take into consideration the reference ambient temperature and the duty cycle!

Consumptions with 100% duty cycle such as lighting, air conditioning or magnetic grippers must be taken into consideration.

100% DC \triangleq $t \geq 10$ min. (according to EN standards)

Dimensioning and Layout

If the ambient temperatures differ from the standard value of 35 °C, the loads must be adjusted. At lower temperatures, the heat release (convection) is better and the rail can handle higher current loads. At higher temperatures, the release of thermal energy to the surrounding air is slower and the load must therefore be reduced.

The corresponding values f_A are taken from the following table:

Ambient temperature			35 °C	40 °C	45 °C	50 °C	55 °C	60 °C	65 °C	70 °C	75 °C	80 °C	85 °C
Standard insulation	Aluminum rails*	f_A	1.0	0.92	0.81	0.76	0.68						
	Copper rails		1.0	0.93	0.87	0.82	0.78						
Heat-resistant insulation	Aluminum rails*	f_A					1.0	0.92	0.81	0.76	0.68	0.63	0.59
	Copper rails						1.0	0.93	0.87	0.82	0.78	0.74	0.72

* The correction factors for Copper **ECO III** correspond to those for aluminum-stainless steel

$$I_{SCHL, G, zul} = I_{SCHL, G, zul, 35\text{ °C}} \cdot f_A \quad I_{SCHL} = \text{rated current of the conductor rail for the specific ambient temperature}$$

C. Calculating the voltage drop

After selecting the rail type based on the calculated total current depending on duty cycle and ambient temperature, the voltage drop must be checked. The calculated voltage drop must be under the value specified by the customer. Typical values here are 2-5%, or 10% in exceptional cases. If the voltage drop is too high, the voltage might be too low to all the drives to start.

The following formulas are used for the calculation:

For direct current	$\Delta U_{35\text{ °C}} = 2 \cdot I \cdot l_G \cdot R$	[V]	$\Delta U_{35\text{ °C}}$ = voltage drop at 35 °C	[V]
			I = total current	[A]
			R = resistance of the conductor rail	[Ω/m]
For alternating current	$\Delta U_{35\text{ °C}} = 2 \cdot I \cdot l_G \cdot Z$	[V]	Z = impedance of the conductor rail	[Ω/m]
			l = feed length	[m] ¹⁾
For three-phase power	$\Delta U_{35\text{ °C}} = \sqrt{3} \cdot I \cdot l_G \cdot Z$	[V]	L = conductor rail length	[m]

Note: l_G here is the portion of the load current “drawn” during start-up.

¹⁾ see feed variants

This consists of the basic load, like lighting and air conditioners, and the start-up currents of the drives I_A .

For start-up current, the following applies:	Three-phase asynchronous drive in direct start	$I_A = I_N \times 5$ to 6 (up to max. 21 kW permitted)	I_G = total current
	Slip ring rotor motor	$I_A = I_N \times 3$ to 5	I_A = Total current consumption when starting
	Frequency converter	$I_A = I_N \times 1.4$ to 1.8	

The length l is the distance between the power feed and end position of the conductor rail segment on which the consumer is located when starting.

If the average ambient temperature is significantly over 35 °C, the voltage drop must be calculated using the following formulas:

$\Delta U\sigma = \frac{\Delta U_{35\text{ °C}}}{f_V}$	[V]	$\Delta U\sigma$ = voltage drop at higher ambient temperature than 35 °C	[V]
		$\Delta U\sigma$ % = voltage drop at ambient temperature over 35 °C	[%]
$\Delta U\sigma \% = \frac{\Delta U\sigma}{U_N} \cdot 100$	[%]	U_N = rated voltage [V]	
		f_V = reduction factor	

To calculate the value f_V , the working temperature must first be calculated.

$\sigma_{AT} = \sigma_{UT} + \Delta\sigma_{SW} = \sigma_{UT} + 30$	[°C]	σ_{AT} = working temperature [°C]
		σ_{UT} = ambient temperature [°C]
		$\Delta\sigma_{SW}$ = temperature increase due to current heating [°C] (use a constant +30 °C)

The value f_V is based on the working temperature and the conductor rail selected and should be taken from the table “Correction factors for the voltage drop ΔU for different ambient temperatures” on page 24.

Dimensioning and Layout

Correction factors for the voltage drop ΔU at different ambient temperatures

Ambient temperature		35 °C	40 °C	45 °C	50 °C	55 °C	60 °C	65 °C	70 °C	75 °C	80 °C	85 °C	
Working temperature / conductor temperature		65 °C	70 °C	75 °C	80 °C	85 °C	90 °C	95 °C	100 °C	105 °C	110 °C	115 °C	
Standard insulation	Aluminum rails 500 A*	fv	0.965	0.960	0.954	0.948	0.943						
	Aluminum rails 800 A*		0.976	0.972	0.968	0.964	0.960						
	Aluminum rails 1000 A*		0.983	0.980	0.977	0.974	0.971						
	Copper rails 500 A		0.959	0.952	0.945	0.938	0.932						
	Copper rails 800 A		0.983	0.980	0.977	0.974	0.971						
	Copper rails 1250 A		0.993	0.992	0.991	0.990	0.989						
Heat-resistant insulation	Aluminum rails 500 A*	fv					0.943	0.937	0.932	0.926	0.920	0.915	0.909
	Aluminum rails 800 A*						0.960	0.956	0.952	0.948	0.944	0.940	0.936
	Aluminum rails 1000 A*						0.971	0.968	0.965	0.962	0.959	0.956	0.953
	Copper rails 500 A						0.932	0.925	0.919	0.912	0.905	0.899	0.893
	Copper rails 800 A						0.971	0.968	0.965	0.961	0.958	0.955	0.952
	Copper rails 1250 A						0.989	0.987	0.986	0.985	0.984	0.982	0.981

* The correction factors for Copper **ECO III** correspond to those for aluminum-stainless steel.

If the voltage drop is too high, then either the number of power feeds must be increased or a larger conductor rail must be selected. Additional power feeds are usually a better technical and commercial alternative than larger conductor rails or costly copper rails.

Working temperature: permanent rail temperature occurring at rated current (ambient temperature + electrical thermal heating)

Max. working temperature: short-term ($t < 30$ sec) 125 °C (in heat-resistant variant)

Possible power feed locations: The power feed arrangement must be appropriate for the specific case, since the voltage drop is calculated with the feed length " l " that falls between the power feed and the end of the conductor rail. The following power feed options are normally used:

End power feed

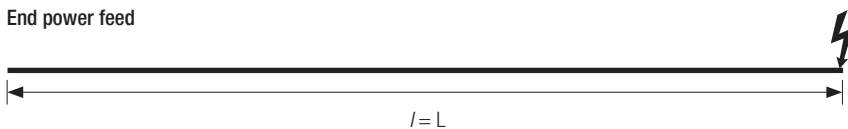

Middle power feed

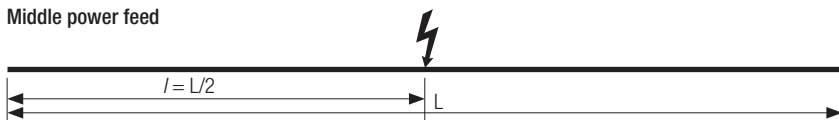

Power feed on both sides

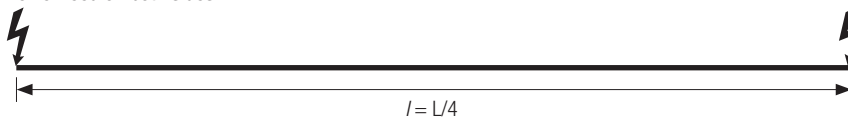

L/6 power feed

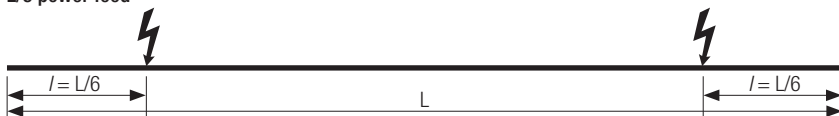

L/10 power feed

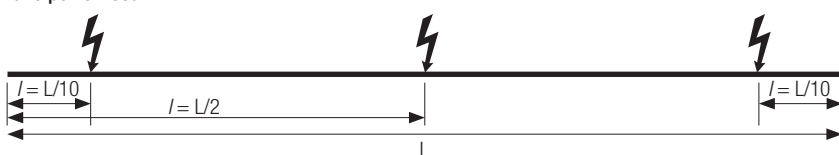

L/14 power feed

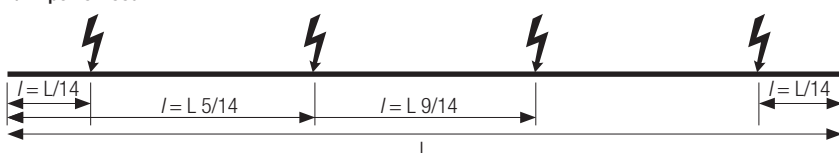

- $l = L$ With an end power feed
- $l = L/2$ With a middle power feed
- $l = L/4$ For power feeds at both ends
- $l = L/6$ For two power feeds each $L/6$ from the ends
- $l = L/10$ For a power feed in the middle and $L/10$ from each end
- $l = L/14$ For four power feed points

L = length of the conductor rail [m]

System Layout

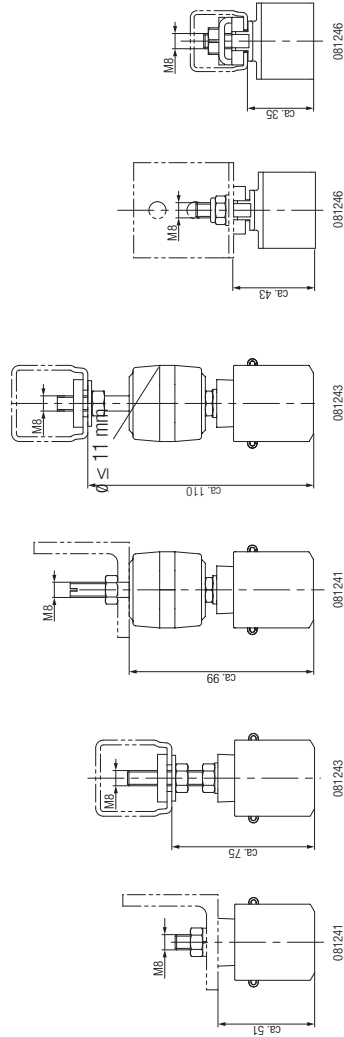
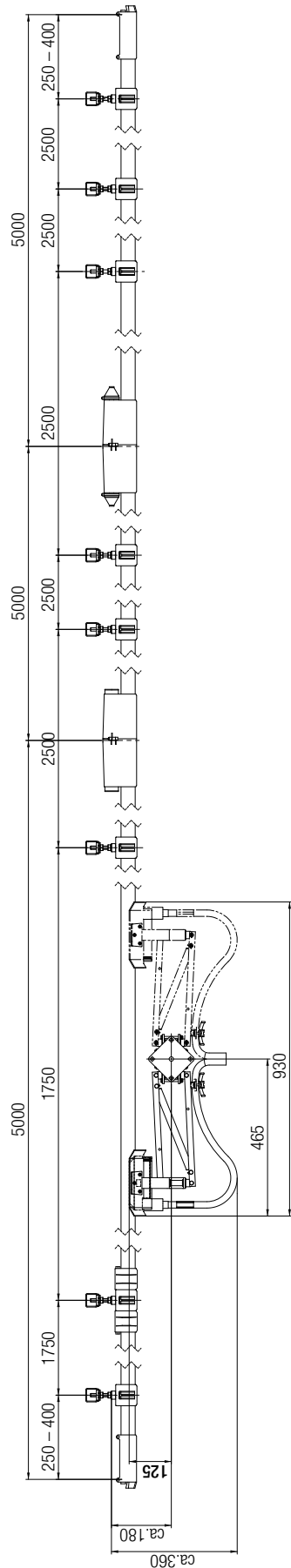

Note: Used outdoors, the conductor rail system must be protected from direct weather exposure as much as possible, for example by installing it under a beam and providing covering the Current Collector (to protect it from snow and ice). Outdoors, insertion of the Current Collector from below is generally preferable to lateral insertion. Also, the use of insulated holders is recommended for outdoor installations. If there is any risk of formation of frost or ice, specify heating conductors in the rail to de-ice the rail and prevent rail damage due to sparking effects on frozen rails (Aluminum rails). Distance between insulation elements and steel structure min. 10 mm.

System Layout

Layout Schematic and Component Overview

Example: 5 m rail

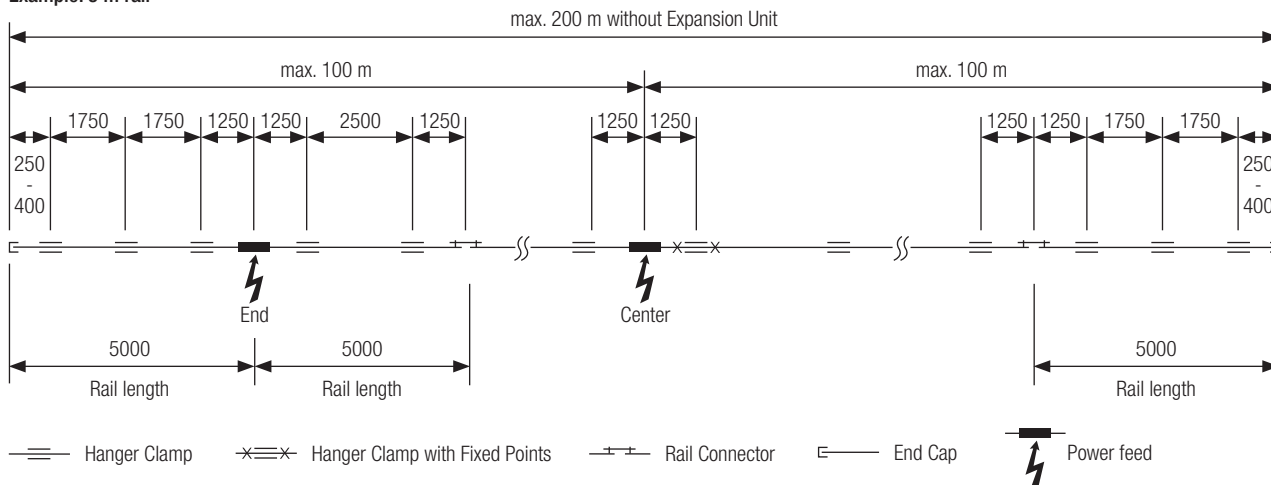

Installation note

Regarding the first and the last conductor rail a support distance of 1750 and 250 mm from the beginning resp. the end of the rail is to be provided. Apart from that the support spacing is 2.5 m. The earth collector should always be installed on the outside. The centre distance between two conductors can be taken from the table below.

Distance between centers of two conductor rails	Standard current collector arrangement	Offset Current Collector arrangement	Current collector arrangement for installations with multi-poled Pickup Guides*
Minimum distance a [mm]	80	70	80

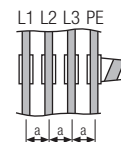

* See mounting instructions for Pickup Guides.

Example material overview / example order

Here is a typical crane conductor rail system that is 57 m in total length, with 4 poles, 800 A, with all accessories, Current Collectors and Support Arms. The required Bill of Materials is listed below. The order quantity should be increased by an assembly reserve for the parts marked with an (x).

Part Description	Part No.	Quantity Needed
Conductor Rail "Phase" 5 m long	081314-5X11*	33
Conductor Rail "Phase" 2 m long	081314*-2X11*	3
Conductor Rail "PE" 5 m long	081314-5X12*	11
Conductor Rail "PE" 2 m long	081314-2X12*	1
Hanger Clamp (x)	081343-01	96
Anchor Clamp	081331-1	8
Rail Connector (x)	081321-2	40
Power Feed	081351-2	4
Tubular Cable Lug 95 mm ² (x)	080052-95	8
End Cap (x)	081371	8
Current Collector "Phase"	081301-2X1	3
Current Collector "PE"	081301-2X2	1
Extension Arm	020197-630	1
Support Arm	020186-500	24
Girder Clip	020286	24
Mounting Comb	081046	1
Conductix-Wampfler Contact Grease (x)	080021	1
Sliding Contact (replacement part) (x)	081003-11	4

Note:

To avoid strand breakage due to external force on the Current Collector, the connection cable should be fine-stranded and highly flexible. The transition to the customer-provided fixed cabling should be directly behind the Current Collector in a terminal box provided by the customer. Long connection cables to Current Collectors should be avoided to reduce maintenance problems.

Layout Examples

Standard Current Collector Layout

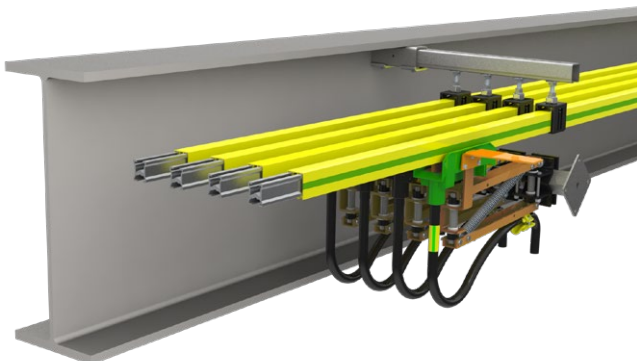

Horizontal installation of conductor rails /
insertion of Current Collectors from below

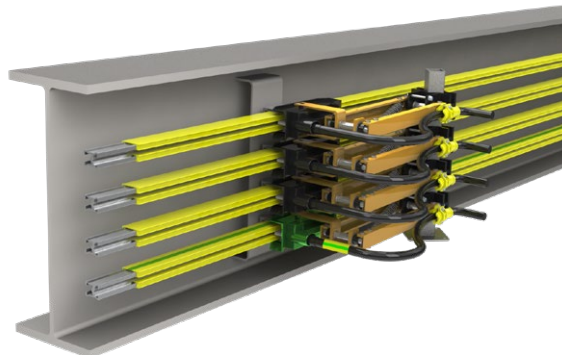

Lateral installation of conductor rails /
insertion of Current Collectors from the side

Offset Current Collector Arrangement

Vertical and horizontal
insertion of Current Collectors

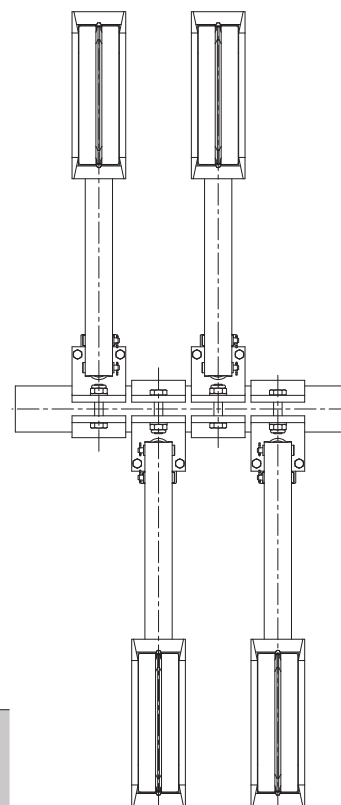
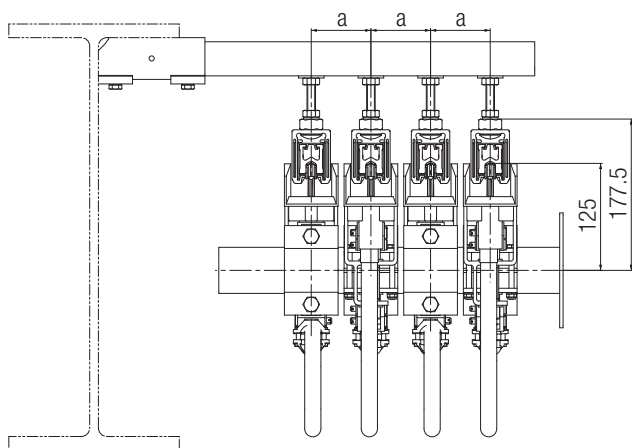

For installations without transfer points the current collectors for vertical and horizontal operation can be staggered. This way the centre distance between two conductor rails is reduced by 10 mm.

Distance between centers of two conductor rails	Standard current collector arrangement	Offset Current Collector arrangement	Current collector arrangement for installations with multi-poled Pickup Guides*
Minimum distance a [mm]	80	70	80

* See mounting instructions for Pickup Guides.

Installation note

Please note that the centre line of the current collector is mounted to the centre line of the conductor rail. The distance between towing arm and conductor rail must be set according to the dimension indicated in above table and sketches.

Mounting Accessories

Support Arms 40 × 40 × 2,5 mm - perforated

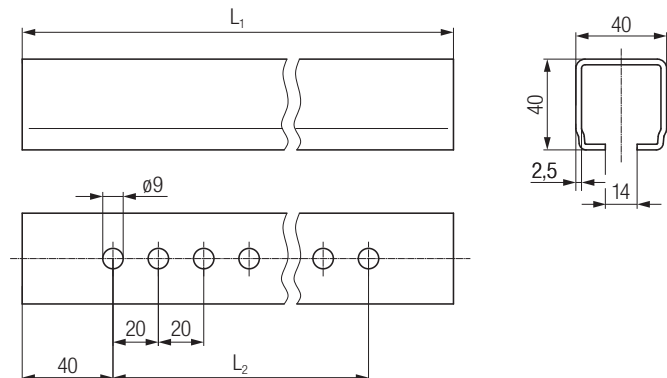
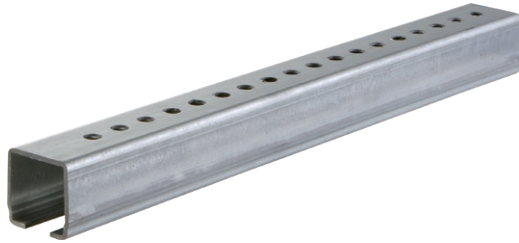

Part No.	L ₁ [mm]	L ₂ [mm]	Material	Weight [kg]
020186-0250	250	200	Galvanized steel	0.625
020186-0315	315	260		0.785
020186-0400*	400	340		1.000
020186-0500*	500	340		1.250
020186-0630*	630	340		1.575
020186-0800	800	340		2.000

* Standard range

Permissible load for Support Arms 40 x 40 mm

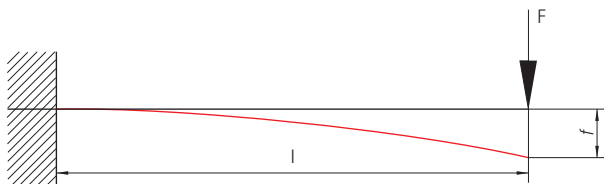

	l [m]							
	0.25	0.32	0.40	0.50	0.63	0.80	1.00	1.25
F [daN]*	164.5	128.5	103.0	82.5	65.5	51.3	41.0	32.9
f [cm]	0.06	0.10	0.16	0.25	0.40	0.63	1.07	1.68

* Calculated with $\sigma = 140 \text{ N/mm}^2$ voltage

f = associated max. deflection

Mounting Accessories

Holder for Support Arms 40 × 40 × 2,5 for screw mounting with 2-holed connector plate

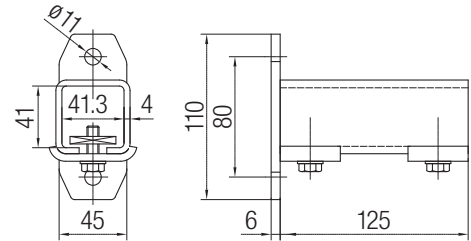
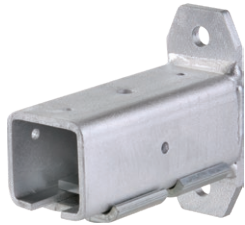

Part No.	Description	Suitable for Support Arm	Weight [kg]
020282	Galvanized steel	020186	1.000

Holder for Support Arms 40 × 40 × 2,5

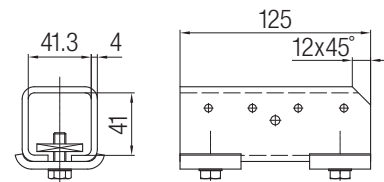

Part No.	Description	Suitable for Support Arm	Weight [kg]
020286	Unplated steel with galvanized hardware	020186	0.730

Mounting Accessories

Girder Clips, clamping thickness 4 - 20 mm



Part No.	Description	Weight [kg]
020180-08*	Galvanized steel	0.150
020480-08	Stainless steel (V4A)	0.150

* Standard range

Clamping thickness s [mm]	4	6	8	10	12	16	20
Installation height h [mm]	31	32	33	34	35	37	40

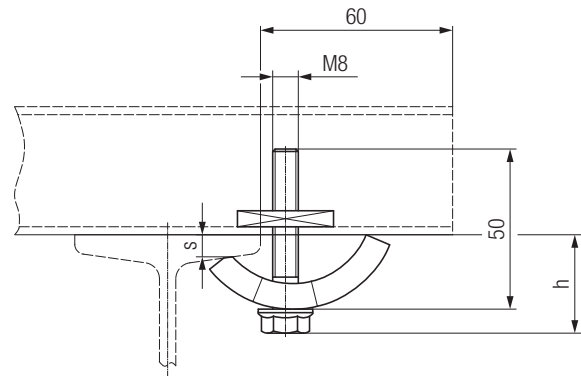

Girder Clips, clamping thickness 18 - 36 mm



Part No.	Description	Weight [kg]
020180-08X36	Galvanized steel	0.220
020480-08X36	Stainless steel (V4A)	0.220

Clamping thickness s [mm]	18-20	20-24	24-28	28-32	32-36
Installation height h [mm]	42-44	44-48	48-52	52-56	56-60

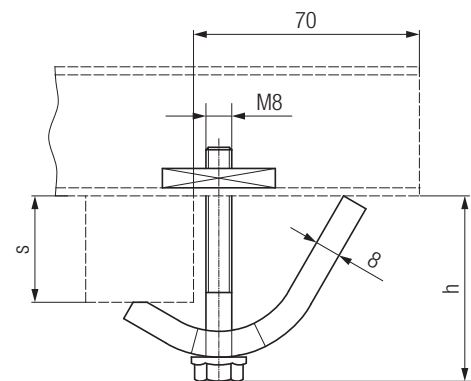

Girder Clips, non-twistable, clamping thickness 6 - 25 mm



Part No.	Description	Weight [kg]
020181-08	Galvanized steel	0.190

Clamping thickness s [mm]	6-25
Installation height h [mm]	32-40

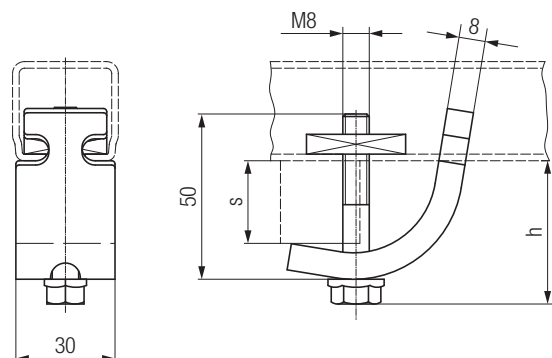

Mounting Accessories

Towing Arms

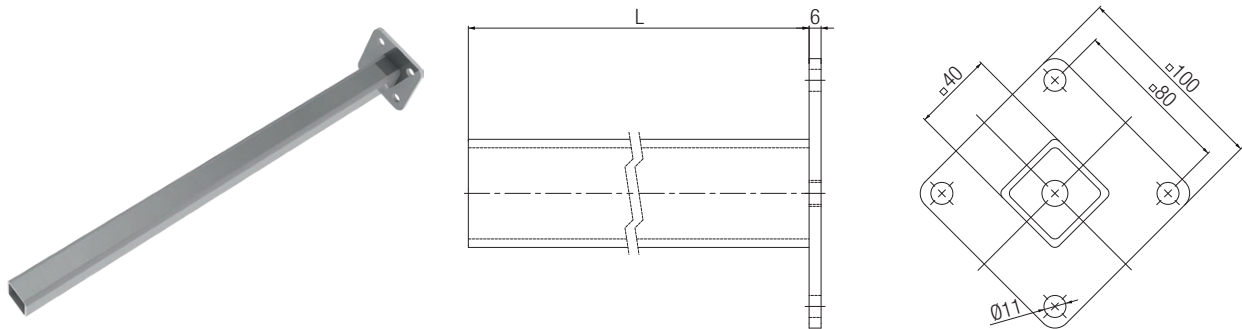

Part No.	Description	L [mm]	Weight [kg]
020197-400	Galvanized steel	400	2.0
020197-630*		630	2.5
020197-800		800	3.0

* Standard range

End Caps

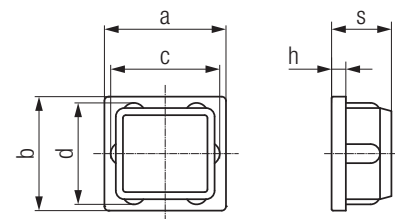

Part No.	For C-rails	Description	a [mm]	b [mm]	c [mm]	d [mm]	s [mm]	h [mm]	Weight [kg]
020662-30	023200	Plastic	30	32	27	29	4	18	0.005
020662-31	023201		30	30	28	28	5	16	0.004

Insulators

Insulators for indoor applications with high contamination and/or applications outdoors, up to 1000 V rated voltage
Only for suspended installation.

Creepage distance 62 mm
Cantilever strength > 350 daN
Ambient temperature -30 °C to +85 °C

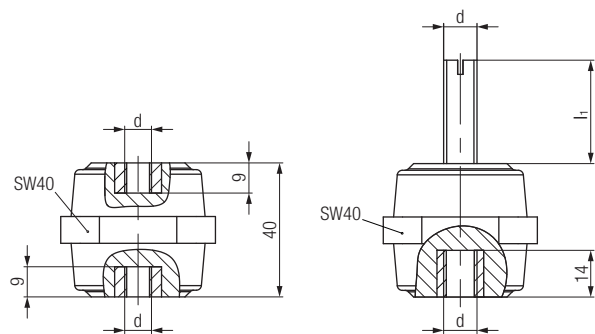
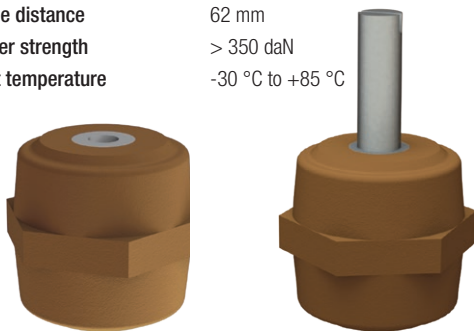

Part No.	Hardware	d	l ₁ [mm]	Weight [kg]
080401-10X10	Inner threading on both ends	M10 / M10	-	0.09
080402-1030X10	Threaded bolts, galvanized	M10 / M10	30	0.98
080403-1030X10	Threaded bolts, stainless steel	M10 / M10	30	0.98

Mounting Accessories

Junction Box for Power Feed, with Fittings, Clamps and Accessories

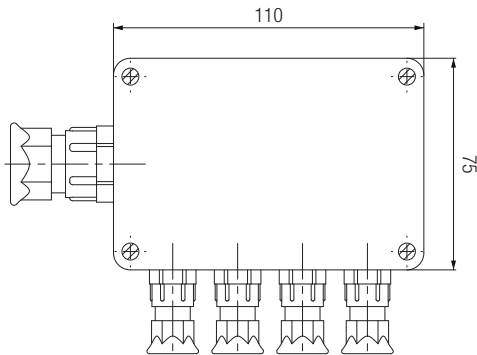

Part No.	Designation	Weight [kg]
080102-3	Junction Box with 3 poles	0.300
080102-4	Junction Box with 4 poles	0.310
080102-5	Junction Box with 5 poles	0.320

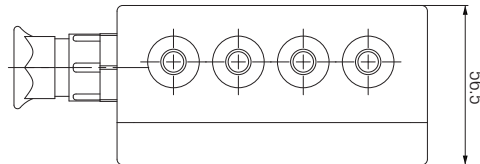

Junction Box for Power Feed, with Fittings, Clamps and Accessories

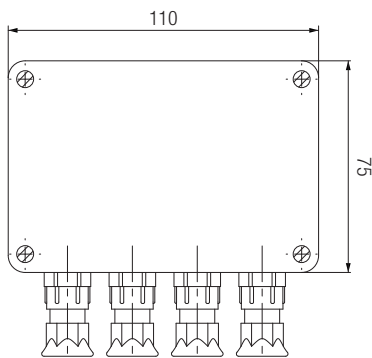

Part No.	Designation	Weight [kg]
080103-3	Junction Box with 3 poles	0.290
080103-4	Junction Box with 4 poles	0.300
080103-5	Junction Box with 5 poles	0.310

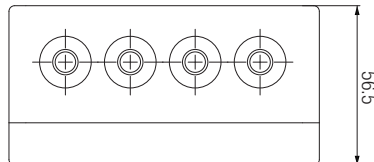

Mounting Comb 081046

For setting the rail holder spacing while mounting the Support Arms

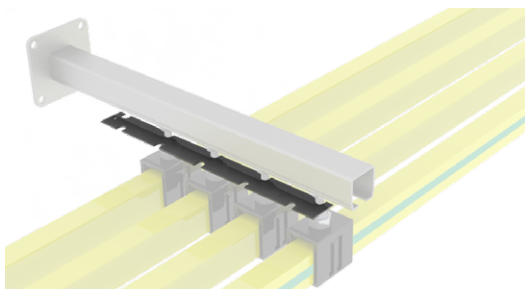

Part No.	Designation	Weight [kg]
081046*	Mounting Comb	0.190

* Standard range

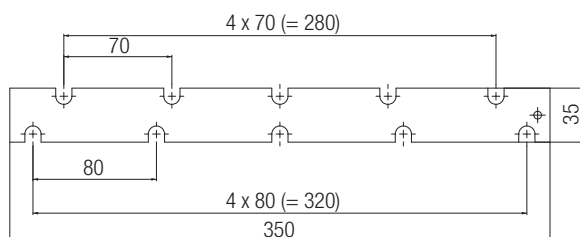

Tools and Assembly Accessories

Grounding- and Short-circuit Device

Protective device during service and maintenance work on the conductor rail

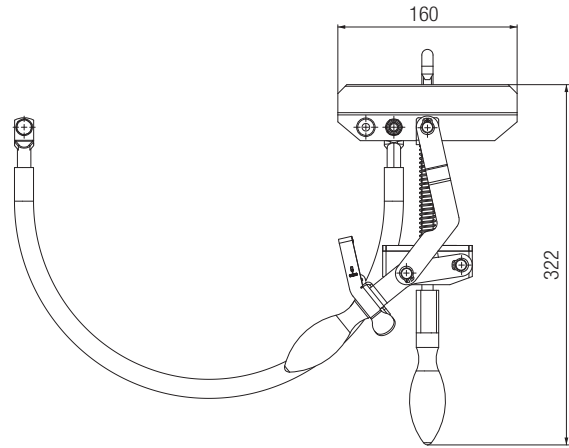

Part No.	Designation	Weight [kg]
08-V015-0441*	Grounding Device 813 with one pole	2.2

* Standard range

Note: Several devices have to be used, depending on the number of poles (all live rails + ground rail). The modular design of the Devices allows for any number of them to be connected. Four Devices have to be used for a 3-phase system (1 x PE + 3 x PH = 4).

Contact Grease for Connection Points (Aluminum rails/CopperECO III rails)



Part No.	Designation	Weight [kg]
080021*	Contact Grease	0.250

* Standard range

** Packing unit: 5 tubes each 50 gram

Application: Use contact grease to avoid corrosion at contact points. A thin film is applied with finger or brush to the faces of the conductor rail and the clamping area of the connectors. One tube will last for about 200 connection points.

Disassembly Tool (Set) for Hanger Clamp removal



Part No.	Designation	Weight [kg]
08-V015-0493	Disassembly Tool	0.396

Application: The Disassembly Tool set comprises two separate tools and eases parting the hanger clamps from the conductor rails.

Replacement Parts

Sliding Contacts

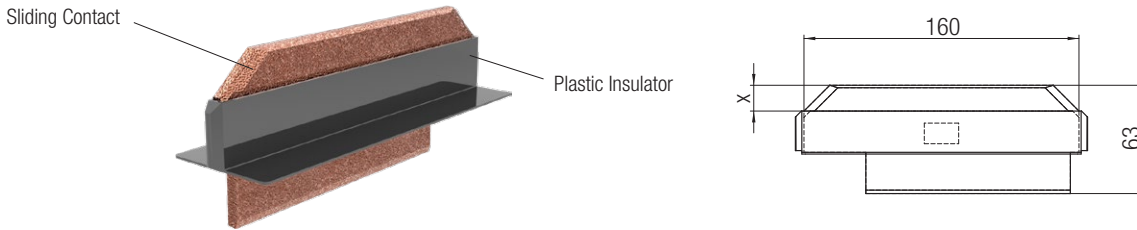

The sliding contact is protected by a plastic insulator, so that accidental contact with live parts of the engaged Current Collector is not possible.

Part No.	Designation	Ampere [A]	Wearing Height X	Weight [kg]
081003-11*	Sliding contact	250	15	0.30

* Standard range

Installation note: When replacing the sliding contact, it is not necessary to remove the collector insulation, it is designed as a plug-in contact (not a screw contact). Plastic insulator is included.

Replacement Parts for Current Collectors

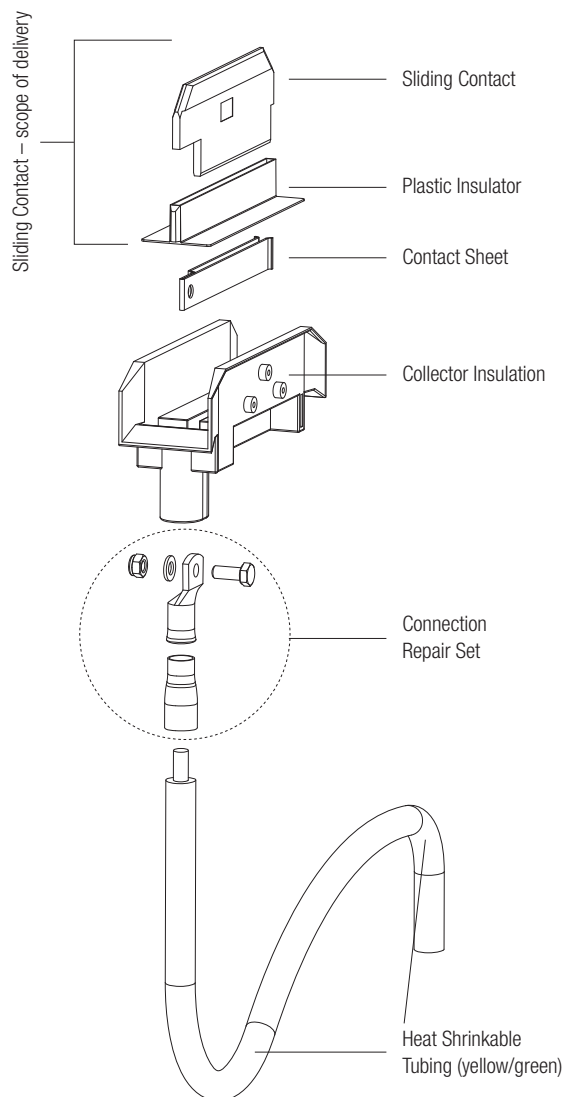

Part No.	Designation	Weight [kg]
08-A150-0006-001	Collector Insulation PH	0.1
08-A150-0006-002	Collector Insulation PE	0.1
08-K154-0394	Connection Repair Set, including: 1 × Contact Sheet (1847) 1 × Tubular Cable Lug (27633) 1 × Heat Shrinkable Tubing black, 55 mm (25662) 10 × Heat Shrinkable Tubing yellow/green, 50 mm (3041397) 1 × Hexagonal Screw DIN933 M8 x 20 (998) 1 × Lock-nut DIN985-M08-A4 (581) 1 × Washer DIN125-A8, 4-A4 (686)	0.6
	Connecting Cable	
	Connecting Cable (pre-assembled) – on request	

* Standard range

(SAP KONFIG 08130X-KOPF-PXL)

Your Applications – our Solutions

The solutions we deliver for your applications are based on your specific requirements. In many cases, a combination of several different Conductix-Wampfler systems can prove advantageous. You can count on Conductix-Wampfler for hands-on engineering support together with the optimum solution to safely meet your needs.

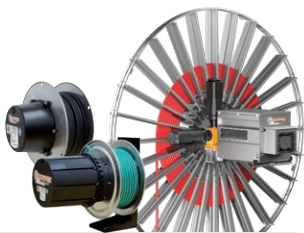

Cable and Hose Reels

Motor driven and spring driven reels by Conductix-Wampfler provide energy, data and media over a variety of distances, in all directions, fast and safe.



Festoon Systems

Conductix-Wampfler cable trolleys can be used in virtually every industrial application. They are reliable, robust and available in an enormous variety of dimensions and designs.

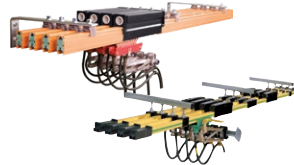

Conductor Rails

Available as enclosed or multiple unipole systems, Conductix-Wampfler conductor rails reliably move people and material.

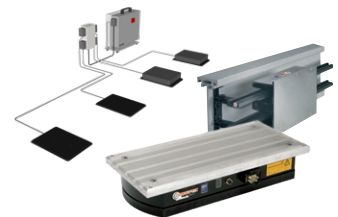

Inductive Power Transfer IPT®

The no-contact system for transferring energy and data. For all tasks that depend on high speeds and absolute resistance to wear. Flexible installation when used with Automated Guided Vehicles.



Non-insulated Conductor Rails

Robust, non-insulated aluminum conductor rails with stainless steel cap provide the ideal basis for power supply of people movers and transit networks.



Radio Remote Controls

Safety remote control solutions customized to meet our customer needs with modern ergonomic design.



Reels, Retractors and Balancers

Available for hoses and cables, as classical reels or high-precision positioning aids for tools, we offer a complete range of reels and spring balancers.



Jib Booms

Complete with tool transporters, reels or an entire media supply system – safety and flexibility are key to the completion of difficult tasks.



Slip Ring Assemblies

Whenever things are really “moving in circles”, the proven slip ring assemblies by Conductix-Wampfler ensure the flawless transfer of energy and data. Here, everything revolves around flexibility and reliability!



Mobile Control Systems

Mobile control solutions for your plant – whether straightforward or intricate. Control and communication systems from LJU have been tried and tested in the automotive industry for decades.



ProfidAT

This data transfer system is a compact slotted waveguide and furthermore can be used as Grounding rail (PE) as well as positioning rail at the same time.

www.conductix.com

Conductix-Wampfler

has just one critical mission:

To provide you with energy and data transmission systems that will keep your operations up and running 24/7/365.

To contact your nearest sales office, please refer to:

www.conductix.contact

